

# Smart10 LVL Design Guide





# Smart10 LVL Design Guide

## Scope of this publication

This Design Guide and Load Tables assist in the selection of Smart10 LVL for a limited number of common structural arrangements met in domestic construction.

Methods of developing lateral restraint and providing adequate support, adequate anchorage against wind uplift, and overall structural stability are outside the scope of this publication, however some limited examples have been reproduced within this document.

Information on the above matters can be obtained from AS 1684 Residential timber-framed construction or from a structural engineer experienced in timber construction.

Tilling Timber Pty Ltd have structural engineers at the SmartFrame Design Centre who can be contacted for advice on matters concerning the use of its engineered timber products in timber construction at techsupport@tilling.com.au or on the Techsupport Helpline 1300 668 690.

### Substitution of other products

All load tables in this document are designed using in-grade tested properties of Smart10 LVL as distributed by Tilling Timber Pty Ltd. Other manufacturers' LVL may have different properties and therefore cannot be designed using these span tables.

### Copyright

Copyright of this publication remains the property of Tilling Timber Pty Ltd, and reproduction of the whole or part of this publication without written permission from Tilling Timber Pty Ltd is prohibited.

### Certification

As a professional engineer, qualified and experienced in timber engineering, I certify that the use of the Smart10 LVL members as shown in these tables, and installed in accordance with the provisions of this Design Guide, complies to the National Construction Code (NCC). These span tables have been prepared in accordance with standard engineering principles, the relevant test reports and Australian standards, ie:

- AS 1720.3 Design criteria for timber-framed residential buildings
- AS 1720.1 Timber structures - design methods
- AS 4055 Wind loads for houses
- AS/NZS 4063 Characterisation of structural timber
- AS/NZS 4357 Structural laminated veneer lumber



CRAIG KAY, RPEng, BDC0730, PE0001869, RPEQ 05100, CC5635C, NER  
National Product Engineer

## About Smart10 LVL

### Description

Smart10 LVL is a structural Laminated Veneer Lumber (LVL) manufactured exclusively for Tilling Timber by toll manufacturers in conformance to the quality controlled process requirements of AS/NZS 4357 - Structural Laminated Veneer Lumber.

### Forest stewardship

Smart10 LVL is manufactured from wood fibre from sustainably managed plantation forests and is produced under a PEFC certified chain of custody system. CFCC GB/T 28952-2018, PEFC SAT 2002:2013.

### Product certification

#### Quality



CMI ProdCert

Compliance with process based quality control requirements is third party audited by CMI Certification, and the audits, together with end product testing is used as the basis for Product Certification by CMI ProdCert as a JAS-ANZ accredited Product Certification body.

JAS-ANZ stands for the government established "Joint Accreditation System of Australia and New Zealand" which exists as the peak organisation for accreditation of Product Certification bodies.



### Preservative Treatment options

Smart10 LVL is supplied with H2s glue-line preservative treatment for use South of the Tropic of Capricorn or SmartGuard H2 or H3 post production pressure treatment, with all treatments in conformance to AS/NZS 1604.1:2021.

### Sustainability

Wood is the right choice for a host of construction applications. It is the earth's natural, energy-efficient, and renewable building material. The miracle in today's engineered wood products is that they make more efficient use of the wood fibre resource to make stronger Plywood, Oriented Strand Board (OSB), I-joists, Glued Laminated Timber (GLT) and Laminated Veneer Lumber (LVL). That is good for the environment and good for designers seeking strong, efficient, and striking building design.

For every tonne of wood grown, a young forest produces 1.07 tonnes of oxygen and absorbs approximately 1.47 tonnes of carbon dioxide. This is good news for a healthy planet. Wood is a perfect material for the environment, for design, and for strong, lasting construction.



The information contained in this product brochure is current as at Feb 2025 and is based on data available to Tilling Timber Pty Ltd at the time of going to print. Tilling Timber Pty Ltd has used its reasonable endeavours to ensure the accuracy and reliability of the information contained in this document and, to the extent permitted by law, will not be liable for any inaccuracies, omissions or errors in this information nor for any actions taken in reliance on this information. Tilling Timber Pty Ltd reserves the right to change the information contained in this document without prior notice. It is important that you call the techsupport Helpline on 1300 668 690 to confirm that you have the most up to date information available.

# Designing with Smart10 LVL

The design information contained within this Design Guide is for the 3<sup>rd</sup> party certified properties of Smart10 LVL only. Other manufacturers' LVL may have different properties and therefore cannot be designed using this information.

## Product specification

Veneers:	Thickness:	1.9 - 3.2 mm
	Species:	Masson Pine ( <i>Pinus massoniana</i> ) or Red Pine ( <i>Pinus sylvestris</i> )
	Grade:	CD (Metriguard graded)
	Joints:	Face scarf and overlap
Dimensional tolerances:	Length:	± 10 mm
	Depth:	≤ 200 mm ± 1 mm
		≥ 201 mm ± 2 mm
Thickness:	- 0, +2 mm at 12% moisture content	
Adhesive:	Phenol Formaldehyde (Type "A", AS 2754.1)	
Formaldehyde emission class:	E <sub>0</sub> (Table 1 AS/NZS 4357)	
Treatment:	H2S Glueline treatment to AS 1604.1	

## Limit state design characteristic properties

Timber Strength Properties: <sup>(1)</sup>		
Bending - Edge	f <sub>b</sub>	36 MPa
Bending - Flat	f <sub>b</sub>	36 MPa
Tension Parallel to grain	f <sub>t</sub>	25 MPa
Tension Perpendicular to grain	f <sub>tp</sub>	0.5 MPa
Compression Parallel to grain	f <sub>c</sub>	28 MPa
Compression Perpendicular to grain - Edge	f <sub>p</sub>	10 MPa
Compression Perpendicular to grain - Flat	f <sub>p</sub>	10 MPa
Shear - Edge	f <sub>s</sub>	4.5 MPa
Average Elastic Modulus	E	10,000 MPa
Average Modulus of Rigidity	G	500 MPa
Average Density		580 kg/m <sup>3</sup>
Moisture Content		12-15%
Joint strength	Face	JD4
	Edge	JD4
	End (stud screw)	JD4

(1) Dry conditions

## Strength reduction factor

The strength reduction factor for calculating the design capacities of structural members shall be taken from the table below, referenced from AS 1720.1 –2010.

Application of SmartLVL as a structural member		
Category 1	Category 2	Category 3
Structural members for houses for which failure would be unlikely to affect an area greater than 25 m <sup>2</sup> ;  OR secondary members in structures other than houses	Primary structural members in structures other than houses;  OR elements in houses for which failure would be likely to affect an area* greater than 25 m <sup>2</sup>	Primary structural members in structures intended to fulfil essential services or post disaster function
<b>Strength reduction factor <math>\phi</math> *</b>		
0.95	0.90	0.80

\* AS 1720.1:2010 Table 2.1

## Duration of load factor

The duration of load factor k<sub>1</sub> for strength are defined within Table 2.3 and clause 1.2.4.1.1 of AS 1720.1.

The duration of load factors j<sub>2</sub> and j<sub>3</sub> for stiffness is defined within clause 1.2.4.1.2 of AS 1720.1

## Moisture effects

When used in dry conditions where the moisture content remains below 15%, no modification for moisture content is required. Where SmartLVL is subjected to conditions, such that the average moisture content for a 12 month period with exceed 15%, the modification factors for strength k<sub>4</sub> and for stiffness j<sub>6</sub> in the following table.

Property	Equilibrium moisture content (EMC)		
	≤15%	15% to 25%	≥25%
Bending and compression	k <sub>4</sub> = 1	k <sub>4</sub> = 1.45 - 0.03 EMC	k <sub>4</sub> = 0.7
Tension and shear	k <sub>4</sub> = 1	k <sub>4</sub> = 1.30 - 0.02 EMC	k <sub>4</sub> = 10.8
Modulus of elasticity	J <sub>6</sub> = 1	j <sub>6</sub> = 1.30 - 0.02 EMC	J <sub>6</sub> = 0.8

## Temperature

The modification factor for temperature K<sub>6</sub> is described in clause 2.4.3 of AS 1720.1

## Length and position of bearing

The bearing area factor k<sub>7</sub> is defined within clause 8.4.5 of AS 1720.1

## Load sharing

Because of the reduced variability of strength values of LVL compared to solid timber, the load sharing factors k<sub>9</sub> within clause 2.4.5 of AS 1720.1 do not apply and therefore k<sub>9</sub> = 1.0.

## Stability

The stability factor k<sub>12</sub> is defined within clause 3.2.4 and 3.3.3 of AS 1720.1 for dry timber except that the material constant (ρ<sub>b</sub> or ρ<sub>c</sub>) for beams and columns shall be calculated as per clause 8.4.7 of AS 1720.1.

## Size factor

The characteristic values in bending and tension for wood products is affected by a size factor. For SmartLVL, multiply the published characteristic strength and tension values by the size factors shown in the table below.

Bending		
Beam orientation	Depth of section	Strength adjustment
Edge	≤90 mm	Nil
	> 90 mm	(90/d) <sup>0.167</sup>
Flat	> 45 mm	(45/t) <sup>0.333</sup>
Tension		
	Largest cross sectional dimension	Strength adjustment
	≤150 mm	Nil
	> 150mm	(150/d) <sup>0.167</sup>

Where:

d = depth of member on edge

t = thickness of member



# Durability and exposure to moisture

## Storage and handling of Smart10 LVL

- Store Smart10 LVL flat on a hard, dry surface
- If surface isn't paved, the ground should be covered with a polythene film
- Keep covered with waterproof material that allows bundles to "breathe"
- Use bearers (bolsters) between the ground and the first bundle (4 metre max spacing)
- Use 100 x 50 timber flat between bundles at same spacing as bolsters
- Take great care to rewrap remaining material after opening bundles
- LVL "grows" in thickness and depth when allowed to get wet....KEEP DRY!
- LVL with high MC has short term reduction in Characteristic Strengths .... KEEP DRY!
- Under NO circumstances is stored SmartLVL to be in contact with the ground.



Smart10 LVL is manufactured from veneers which have a natural durability rating of class 4, which is the same rating as some Ash type Eucalypts and Radiata Pine. Untreated Smart10 LVL should not be used where the equilibrium moisture content is likely to remain above 20% for an extended period.

Non-preservative treated, H2f and H2 preservative treated Smart10 LVL is suitable as studs in the **internal, fully protected, ventilated** and the **external above ground, protected** zones of the structure as shown below. Smart10 LVL is not suitable for **external above ground, exposed** or humid indoor conditions, such as swimming pool enclosures.

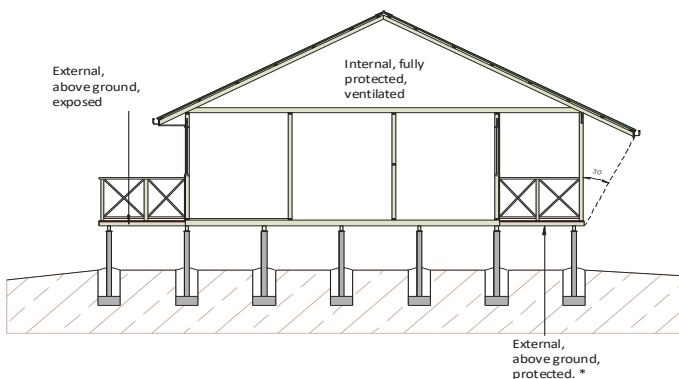

Definitions of exposure zones within a structure

## Moisture effects on Smart10 LVL

Smart10 LVL, like all wood products, is hygroscopic, which means it has an affinity for water, and being a LVL, should be considered as a composite of many pieces of wood, each with different potential swelling. Moisture exposure will ultimately lead to dimensional change.

Smart10 LVL is supplied with a short term construction water repellent however once framed into a structure may be exposed to the weather for a limited time (usually not greater than 3 months) without negative affect, BUT, it may exhibit some effects of this exposure such as swelling and checking (especially at cut ends), depending upon the weather conditions.

While the products will withstand normal exposure, excessive exposure during distribution, storage or construction may lead to dimensional changes that affect serviceability. These changes include cupping, bowing or expansion to dimensions to beyond the specified tolerance of the product in the "as-manufactured" condition.

Individual members of a laminated multi stud may exhibit some cupping if water becomes trapped between the laminates. This cupping produces more of a visual and possible fixity problem rather than being structurally significant. If not properly dried out, this moisture between laminated members may lead to decay.

As an organic material, mould and mildew may grow on untreated wood products if moisture is present. Prolonged periods of high moisture may also support the growth of wood decay fungi.

In critical applications where dimensional change due to moisture exposure is to be absolutely minimised it is recommended that spray on short term repellent (or bulk for airless spray guns) be used to seal any cut ends or notches etc.

The table below shows the moisture content of LVL as a function of humidity.

Moisture content of wood products % <sup>(1)</sup>	
Relative Humidity %	LVL MC
10	1.2
20	2.8
30	4.6
40	5.8
50	7.0
60	8.4
70	11.1
80	15.3
90	19.4

1. Approx. moisture content at 21°C

## Dimensional change

Smart10 LVL will shrink and swell in proportion to changes in moisture content between 0 and 28 % fibre saturation point.

The most significant moisture movement will occur across the grain (tangential and radial directions within a log). Longitudinal (movement in the grain direction) may be a factor depending upon the type of structure. Detailing of Smart10 LVL to be used where moisture contents will cycle should allow for dimensional instability.

The AVERAGE amount of dimensional change in a piece of Smart10 LVL changes in moisture content can be APPROXIMATED by the following formula:

$$\Delta D = D_i S (MC_i - MC_f) / FSP$$

## Durability and exposure to moisture (Cont'd)

Where:

$\Delta D$  = change in dimension

$D_i$  = Initial dimension

$S$  = Shrinkage coefficient = approximately 6-8 %

$MC_i$  = Initial moisture content

$MC_f$  = final moisture content

$FSP$  = fibre saturation point approximately 28%

HOWEVER, these dimensional effects are quite variable. Thickness swell in LVL is erratic along the length because of the densification of the lap joints during manufacture tends to "relieve" when saturated and the total swell in sections containing two (2) laps can be as much as 4 mm.

### Change in characteristic strengths

Changes in moisture content in wood results in changes in mechanical properties, with higher properties at lower moisture contents. Estimates of the effect of moisture differentials on the properties of clear wood may be obtained by the following equation:

$$P = P_{12} \left( \frac{P_{12}}{P_g} \right)^{\left( \frac{12-M}{M_p-12} \right)}$$

Where:

$P$  = Characteristic property at moisture content

$P_{12}$  = same Characteristic property at 12% moisture content

$P_g$  = same Characteristic property for Green wood

$M_p$  = Intersection moisture content = 24%

Characteristic Property		% Reduction in characteristic strength at % MC					
		14	16	18	20	22	24
MOE (Stiffness)	E	3.3	6.5	9.7	12.7	15.6	18.4
MOR (Bending)	$F'_b$	8.4	16.1	23.1	29.6	35.5	40.9
Compression perpendicular to grain	$f'_p$	9.9	18.9	27.0	34.2	40.8	46.7
Compression parallel to grain	$f'_c$	11.0	20.7	29.4	37.2	44.1	50.2
Shear	$f'_s$	6.6	12.8	18.6	24.0	29.0	33.7

### Supplementary information - wall frame fabricators

Smart10 LVL will swell if it receives significant moisture ingress, and not all of that swell will be recovered once the LVL's moisture content has stabilised to the equilibrium moisture content typically found in an enclosed house frame in Australia.

For multiple studs, the swelling of individual studs, and the water trapped between touching elements may compound to cause lateral displacement in frames and around openings.

The effect of swell can be reduced by:

1. Where possible, ensure that the studs are orientated to have any raised veneer overlaps on the outer faces facing down to minimise the risk of collecting water
2. Keeping the completed frames covered before delivery to site
3. Under sizing the noggings by 1-2 mm to allow for swelling.

Exact length would vary based upon climate, season and accuracy of cut

4. Noggging installation:
  - i. Leave end noggings out of wall frames to require the builders to add at the time of lining to reduce the effect of bowing on frame squareness

Alternatively

  - ii. Install a sliding end noggging at either the top or bottom of the frame that would be fixed onsite by the builder
4. Use the strength of Smart10 LVL to:
  - i. Increase stud spacing where applicable
  - ii. minimise the amount of multiple studs under concentrated loads
5. If the design calls for trenched top and bottom plates, the trenches should be overcut by 4 mm to accommodate the swell of the stud
6. Consider a solid timber bottom plate to minimise plate swelling.

### Supplementary Information - Frame installers

1. Smart10 LVL frames should be enclosed as quickly as reasonable practical, or installed during extended periods of dry weather, to prevent swelling of the LVL sufficient to generate lateral displacement in frames and around openings
2. Maintain good airflow around framing elements and do not allow water to pool on or around element
3. Ensure that floors can drain by creating drainage holes in the floor substrate
4. Remove bottom plates in door openings as soon as possible to prevent longitudinal swelling in the bottom plate of the frames.
5. Install plasterboard lining 10 mm off the floor as per manufacturers' recommendations to allow for swell that may have occurred in the bottom plate.

### Remedial measures for an excessively swelled frame

In the event that framing does get very wet, and construction is to continue immediately, the following remedial steps are recommended:

1. Enclose the frame as soon as possible
2. Knock out noggings in the wall frames to keep the frame end studs straight. Replace noggings before lining once the framing moisture content is below 20%.
3. Do not line the frames until the moisture content is below 20%
4. If planing is deemed necessary, planing of the top and bottom veneers is allowable to return the thickness of the LVL back to original
5. It is NOT recommended to plane back the depth of the LVL as it will shrink back to an undersized member once equalised to internal moisture content conditions.

# Design of wall studs to AS 1684 (Wall height from 3.0 - 3.6 m)

## Background

Figure 1.1 and Clause 1.6.6 in AS 1684 Parts 2 and 3 mandates a maximum external wall height (floor to ceiling) of 3000 mm. (measured at common external walls, not gable or skillion ends). The corresponding deemed-to-satisfy (DTS) data and tables within the standard is based upon this maximum wall height, especially in the areas of:

- Racking forces - Clause 8.3.4** Total racking force is a function of area of elevation and racking pressures (the maximum wall height assumed to generate the pressures given in Tables 8.1 to 8.5 was 2700 mm even though it was permitted to be used for walls up to 3000 mm high). The pressures in Tables 8.1 to 8.5 are a function of the building geometry such as height to width ratio. Increasing the assumed external wall heights from 2700 mm to 3600 mm increased a significant percentage of the pressures on the projected areas of elevation.
- Bottom plate fixing - Clause 8.3.6.10** Fixing of bottom of bracing walls requires consideration of the uplift at ends of bracing walls which in turn is a function of wall height. Table 8.23 (Table 8.24 in Part 3) therefore requires extension to cater for walls up to 4800 mm high.
- Net wind uplift pressures - Clause 9.6.4** The net wind uplift pressures in Table 9.5 and the uplift forces in Tables 9.6 to 9.11 (Tables 9.6 to 9.10 in Part 3) may be influenced by the overturning forces on the building (see note to Table 9.5). The overturning forces are caused by a combination of both direct uplift and the lateral forces on the building. The taller the building, then the higher the overturning forces will be. The equivalent net uplift pressures are significantly higher for taller buildings (3600 mm high external walls).
- Shear forces on exterior load bearing walls - Clause 9.7.6 and Table 9.29.** The values in Table 9.29 will need to be modified if the wall heights are modified
- Bracing force value in Appendix G** The bracing force values given in the Tables in this Appendix are only applicable to wall heights of 2700 mm. It is not appropriate to apply a simple % increase to cater for wall heights from 3000 mm to 3600 mm, therefore this Appendix should not be used for walls higher than 3000mm.

The overriding 3000 mm height limitation was included in AS 1684 to ensure that other design assumptions and requirements listed above in the Code would not be compromised.

## Designing external wall heights from 3.0 to 3.6 m

The AS 1684 User Guide No 4 June 2012 was developed to provide a recommended Procedure for Wall Heights 3.0 to 3.6 m and is available from WoodSolutions.com.au. The recommendations for wall heights from 3.0 to 3.6 m in this Design Guide listed below are reproduced from that document, and therefore Tilling Timber Pty Ltd will not accept responsibility for the values contained therein.

### 1. Member Sizes

The size of studs, plates and lintels in external load-bearing walls can be determined directly from the relevant span tables in this document.

### 2. Racking Force

The total racking force shall be determined from Clause 8.3.4 but for external wall heights above 3000 mm up to 3600 mm, the lateral pressures determined from Tables 8.2 to 8.5 for roof pitches 50 to 200 shall be increased by 10%.

Note:- Pressures for other roof pitches or for vertical surface elevations (Table 8.1) do not require to be increased.

Determine the capacity of bracing walls greater than 2700 mm high from Table 8.19.

### 3. Fixing of Bottom of Bracing Walls

Include the following additional lines in Table 8.23 of Part 2 and Table 8.24 of Part 3:-

Wall Height (mm)	Uplift force at ends of bracing walls (kN)												
	For modified bracing wall capacity rated at (kN/m)												
	0.5	1.0	1.5	2.0	2.5	3.0	3.5	4.0	4.5	5.0	5.5	6.0	8.0
3300	1.7	3.3	5.0	6.6	8.3	9.9	12	13	15	17	18	20	26
3600	1.8	3.6	5.4	7.2	9.0	11	13	14	16	18	20	22	29
3900	2.0	3.9	5.9	7.8	9.8	12	14	16	18	20	21	23	31
4200	2.1	4.2	6.3	8.4	11	13	15	17	19	21	23	25	34
4800	2.4	4.8	7.2	9.6	12	14	17	19	23	24	26	29	38

### 4. Wind Uplift Forces

In Clause 9.6.4, the wind uplift forces calculated by multiplying the net uplift pressure by the area of roof contributing to tie-down, shall be determined from Table 9.5 using the following net uplift pressures for the tie-down positions described:-

#### Part 2 - Non cyclonic

Connection/tie-down position	Net uplift pressure (kPa)							
	Wind classification							
	N1		N2		N3		N4	
	Sheet Roof	Tile roof	Sheet roof	Tile roof	Sheet roof	Tile roof	Sheet roof	Tile roof
Single or upper storey floor frame to supports	-	-	0.25	-	1.2	0.8	2.4	2.0
Lower storey wall frame to floor Frame or Slab	-	-	0.25	-	1.2	0.8	2.4	2.0
Lower storey floor frame to supports	-	-	-	-	-	-	1.4	1.0

#### Part 3 - Cyclonic

Connection/tie-down position	Net uplift pressure (kPa)					
	Wind classification					
	C1		C2		C3	
	Sheet roof	Tile roof	Sheet roof	Tile roof	Sheet roof	Tile roof
Single or upper storey floor frame to supports	1.5	1.3	2.93	2.7	4.3	4.3
Lower storey wall frame to floor frame or slab	1.5	1.3	2.93	2.7	4.3	4.3
Lower storey floor frame to supports	0.6	0.5	2.0	1.8	4.3	4.3

**Note:** The uplift forces given in Tables 9.6 to 9.10 shall not be used for determination of uplift forces, however they could be recalculated using the net uplift pressure given above

### 5. Shear forces on External Non-loadbearing Walls

Table 9.29 needs to have additional notes added to cater for 3300 mm and 3600 mm high walls:-

NOTES:

For 3300 mm high external walls, multiply the above values by 1.3.

For 3600 mm high external walls, multiply the above by 1.3

### 6. Appendix G

**Appendix G** shall **NOT** be used to determine racking forces for wall heights from 3000 to 3600 mm.

## Notching and holes in Smart10 LVL studs

The following diagram and tables are reproduced from AS 1684.2: 2021, and focused where necessary to only deal with studs.

The paragraph (b) below was introduced into the 2021 edition of AS 1684 to allow for larger holes/notches in non loadbearing

walls, and given the higher characteristic strength values of Smart10 LVL over solid sawn timber studs provides a conservative solution.

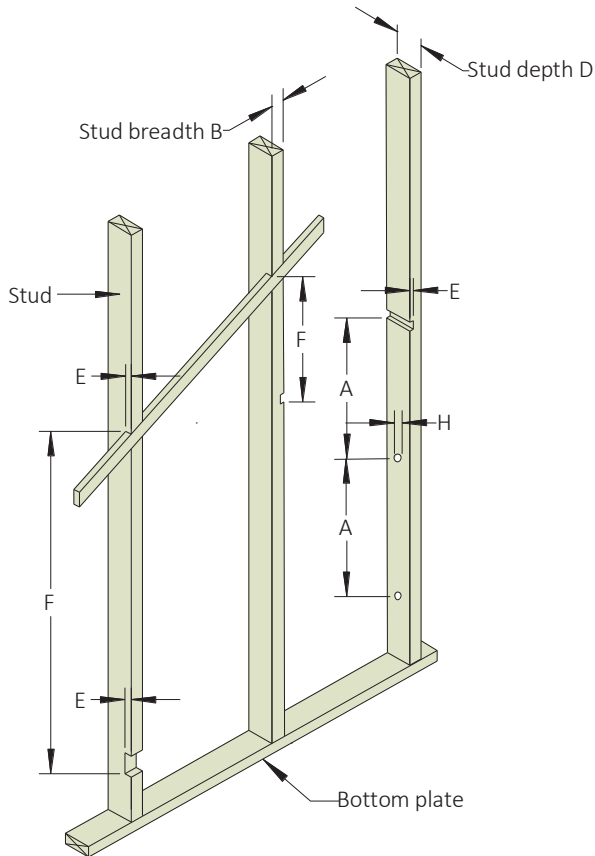

Symbol	Description	Limits	
		Notched	Not notched
A	Distance between holes and/or notches in stud breadth	Min. 3D	Min. 3D
H	Hole diameter (studs and plates)	Max. 25 mm (wide face only)	Max. 25 mm (wide face only)
C	Notch into stud breadth	Max. 10 mm	Max. 10 mm
E	Notch into stud depth	Max. 20 mm (for diagonal cut in bracing only) (see Notes 1 and 2)	Not permitted (see Note 1)
F	Distance between notches in stud depth	Min. 12B	N/A

### NOTES

1. A horizontal line of notches up to 25 mm may be provided for the installation of baths
2. Except as permitted for diagonal cut in bracing, notches up to 20 mm may occur in every fifth individual stud.
3. For additional jamb stud requirements, see Figures 6.5, 6.9(A) and 6.9(B) of AS 1684.2:2021
4. Top and bottom plates in internal non-loadbearing and non-bracing walls may be discontinuous up to 60 mm (cut or drilled) to permit installation of services provided that, at the discontinuity, the plates are trimmed or otherwise reinforced either side of the discontinuity to maintain the lateral and longitudinal integrity of the wall.

### (a) General (external walls, loadbearing walls and braced sections of internal non-loadbearing walls)

The maximum size and spacing of cuts, holes, notches and similar section reductions in studs shall be in accordance with the above diagram.

- i) Holes in studs and plates shall be located within the middle half of the depth and breadth of the member, respectively.
- ii) A longitudinal groove up to 18 mm wide × 10 mm deep may be machined into the middle third depth of a stud to accept full-length anchor rods. Where the groove exceeds this dimension, the remaining net breadth and depth of the stud shall be not less than the minimum size required.
- iii) Studs may be designed as notched or not-notched. For common studs, the maximum notch depth for single or upper storey or lower storey construction shall be 20 mm.
- iv) Jamb studs in external walls and other loadbearing walls shall not be notched within the middle half of their height or within the height of the opening. A notch up to a maximum of 20 mm in depth is permissible outside this region at the top and/or the bottom of the stud.

### (b) Internal non-loadbearing walls (excluding sections of wall that have diagonal or structural sheet bracing installed)

The general requirements for internal non-loadbearing walls (excluding sections of wall that have diagonal or structural sheet bracing installed) shall be as specified in Item (a) above. The following additional allowances are permitted:

- i) Holes in plates and noggings of diameter up to 52 mm may be located on the centre-line of the wide face provided they are spaced a minimum of 1 800 mm apart and are not located adjacent to significant timber defects.
- ii) A single hole in a stud of diameter up to 52 mm may be located on the centre-line of the wide face provided they are not located adjacent to significant timber defects and can only occur not closer than in every fourth stud.
- iii) A single notch in a stud up to 50 % of the stud depth may be used. The notch can only occur not closer than in every fourth stud.



## Index of span tables

Common stud—Single upper storey wall— un-notched	N1-N4	
	450 ctrs	8
	600 ctrs	9
Common stud—Single upper storey wall— un-notched	C1-C3	
	450 ctrs	10
	600 ctrs	11
Common stud—Single upper storey wall— notched	N1-N4	
	450 ctrs	12
	600 ctrs	13
Common stud—Single upper storey wall— notched	C1-C3	
	450 ctrs	14
	600 ctrs	15
Jamb studs		
	N1-N4	16
	C1-C3	18
Wall studs—lower storey load bearing walls—un notched		
	N1-N4	20
	C1-C3	22
Studs lower storey of 2 storey walls - Supporting floor loads only		24
Studs supporting concentrated roof loads		26
Floor joists supporting floor loads only		28
Floor bearers supporting joists loads only		29
Floor bearers supporting joists, walls and roof loads		30
Single span lintels in single/upper storey walls		
	N1-N4	32
	C1-C3	33
Single span lintels in lower storey walls		35
Single/continuous span rafter—with ceiling attached		
	N1-N4	37
	C1-C3	39
Single/continuous span rafter—without ceiling attached		
	N1-N4	41
	C1-C3	43
Ceiling joists	N1-C3	45
Hanging beams —Supporting ceiling loads only	Ni-C3	46
Roof battens - sheet roof		
	N1-N4	47
	C1-C3	48
Tie-down battens - sheet roof		49
Wall top plates - Single upper storey		
	N1-N4	50
	C1-C3	51
Wall top plates—Lower storey of two storeys	All wind zones	52

# Common Stud at 450 mm ctrs - Single/upper storey walls - Un-notched

## AS 4055 Classification N1- N4

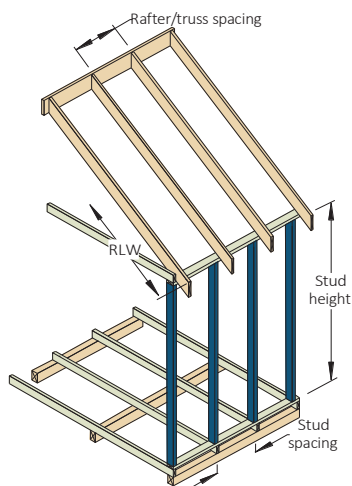

### EXAMPLE:

Sheet roof  
 Stud spacing = 450 mm  
 Rafter truss spacing = 600 mm  
 Stud height = 2700 mm  
 Roof load width = 6500 mm

Enter sheet roof column, 600 mm in rafter/truss spacing column, read down to a span roof load width of 6500 mm in a 2700 mm stud height.

### ADOPT:

Smart10 LVL - 70 x 45

Rafter/Truss spacing (mm)		450	600	900	1200	450	600	900	1200
Size DxB (mm)	Stud Height (mm)	Maximum recommended roof load width (mm)							
		Sheet Roof				Tile Roof			

### Stud spacing 450 mm

70x35	2400	7500	7500	6500	4500	7500	6500	4500	3000
	2700	6500	5500	3500	2500	4500	3500	2500	1800
	3000	3500	2500	1800	NS	2500	2000	NS	NS
70x45	2400	7500	7500	7500	6500	7500	7500	6500	4500
	2700	7500	7500	5500	4500	7500	6000	4000	3000
	3000	6500	5500	3500	2500	4500	3500	2500	1800
	3600	1500	1500	NS	NS	1500	NS	NS	NS
2/70x35	2400	7500	7500	7500	7500	7500	7500	7500	7500
	2700	7500	7500	7500	7500	7500	7500	7500	6500
	3000	7500	7500	7500	5500	7500	7500	5500	4000
	3600	7500	5500	3500	2500	4500	3500	2500	1500
2/70x45	2700	7500	7500	7500	7500	7500	7500	7500	7500
	3000	7500	7500	7500	7500	7500	7500	7500	6000
	3600	7500	7500	5500	3500	7500	5500	3500	2500
90x35	2400	7500	7500	7500	7500	7500	7500	7500	7500
	2700	7500	7500	7500	7500	7500	7500	7500	5500
	3000	7500	7500	7500	5500	7500	7500	5000	4000
	3600	5500	4500	2500	1500	3500	2500	1500	1500
90x45	2700	7500	7500	7500	7500	7500	7500	7500	7500
	3000	7500	7500	7500	7500	7500	7500	7500	5500
	3600	7500	7500	4500	3500	6500	5500	3500	2500
2/90x35	3000	7500	7500	7500	7500	7500	7500	7500	7500
	3600	7500	7500	7500	7500	7500	7500	7500	5500
2/90x45	3600	7500	7500	7500	7500	7500	7500	7500	7500
120x35	3000	7500	7500	7500	7500	7500	7500	7500	7500
	3600	7500	7500	7500	7500	7500	7500	7500	5500
120x45	3600	7500	7500	7500	7500	7500	7500	7500	7500
140x35	3600	7500	7500	7500	7500	7500	7500	7500	7500
140x45	3600	7500	7500	7500	7500	7500	7500	7500	7500
170x35	3600	7500	7500	7500	7500	7500	7500	7500	7500

### NOTES :

1. D = member depth, B = member breadth, NS = not suitable
2. The above table was based on a maximum wall mass of 37 kg/m<sup>2</sup>
3. Multiple studs to be laminated as per AS 1684
4. Stud not notched
5. Maximum tension load in stud not to exceed 8.5 kN. Where studs are nailed laminated the tension load in each stud shall not exceed 8.5 kN.
6. If design stud length (not gable end walls) is > 3000 mm, as a minimum, the DTS provisions within AS 1684 for the racking force (clause 8.3.4), fixing of bottom plate (clause 8.3.6.10), uplift and shear force provisions (clause 9.7.6 and Table 9.2) need to be modified to allow for the extra wall height - See page 4
7. Not all sizes of SmartLVL in this table are stocked in each state. Please check with your supplier before ordering

# Common Stud at 600 mm ctrs - Single/upper storey walls—Un-notched

## AS 4055 Classification N1- N4

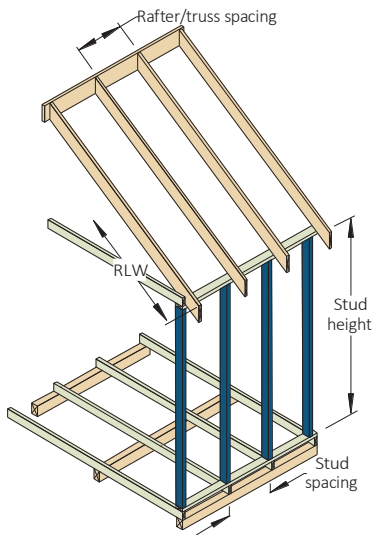

### EXAMPLE:

Sheet roof  
 Stud spacing = 600 mm  
 Rafter truss spacing = 600 mm  
 Stud height = 2700 mm  
 Roof load width = 6500 mm  
 Enter sheet roof column, 600 mm in rafter/truss spacing column, read down to a span roof load width of 6500 mm in a 2700 mm stud height.

### ADOPT:

Smart10 LVL - 70 x 45

Rafter/Truss spacing (mm)		450	600	900	1200	450	600	900	1200
Size DxB (mm)	Stud Height (mm)	Maximum recommended roof load width (mm)							
		Sheet Roof				Tile Roof			
<b>Stud spacing 600 mm</b>									
70x35	2400	6500	6500	4500	3000	4500	4500	3000	2000
	2700	2500	2500	1500	NS	1500	1500	NS	NS
70x45	2400	7500	7500	7500	5500	7500	7500	5500	4000
	2700	6500	6500	4000	3000	4500	4500	3000	2000
	3000	2500	2500	2000	1500	2000	2000	1500	NS
2/70x35	2400	7500	7500	7500	7500	7500	7500	7500	7500
	2700	7500	7500	7500	7500	7500	7500	7500	5500
	3000	7500	7500	6500	4500	6500	6500	4500	3500
	3600	3500	3500	2500	1500	2500	2500	1500	NS
2/70x45	2700	7500	7500	7500	7500	7500	7500	7500	7500
	3000	7500	7500	7500	7500	7500	7500	7000	5500
	3600	6500	6500	4500	3500	4500	4500	2500	2500
90x35	2400	7500	7500	7500	7500	7500	7500	7500	7500
	2700	7500	7500	7500	6500	7500	7500	6500	4500
	3000	7500	7500	5500	4000	5500	5500	3500	3000
	3600	1500	1500	NS	NS	1500	1500	NS	NS
90x45	2700	7500	7500	7500	7500	7500	7500	7500	7500
	3000	7500	7500	7500	6500	7500	7500	6500	4500
	3600	4500	4500	3500	2500	3500	3500	2500	1500
2/90x35	3000	7500	7500	7500	7500	7500	7500	7500	7500
	3600	7500	7500	7500	6500	7500	7500	6500	4500
2/90x45	3000	7500	7500	7500	7500	7500	7500	7500	7500
	3600	7500	7500	7500	7500	7500	7500	7500	6500
120x35	3000	7500	7500	7500	7500	7500	7500	7500	7500
	3600	7500	7500	7500	6500	7500	7500	6500	4500
120x45	3600	7500	7500	7500	7500	7500	7500	7500	7500
140x35	3600	7500	7500	7500	7500	7500	7500	7500	7500
140x45	3600	7500	7500	7500	7500	7500	7500	7500	7500
170x35	3600	7500	7500	7500	7500	7500	7500	7500	7500

### NOTES :

- D = member depth, B = member breadth, NS = not suitable
- The above table was based on a maximum wall mass of 37 kg/m<sup>2</sup>
- Multiple studs to be laminated as per AS 1684
- Stud not notched
- Maximum tension load in stud not to exceed 8.5 kN. Where studs are nailed laminated the tension load in each stud shall not exceed 8.5 kN.
- █ If design stud length (not gable end walls) is > 3000 mm, as a minimum, the DTS provisions within AS 1684 for the racking force (clause 8.3.4), fixing of bottom plate (clause 8.3.6.10), uplift and shear force provisions (clause 9.7.6 and Table 9.2) need to be modified to allow for the extra wall height - See page 4
- Not all sizes of SmartLVL in this table are stocked in each state. Please check with your supplier before ordering

# Common Stud at 450 mm ctrs - Single/upper storey walls - Un-notched

## AS 4055 Classification C1 - C3

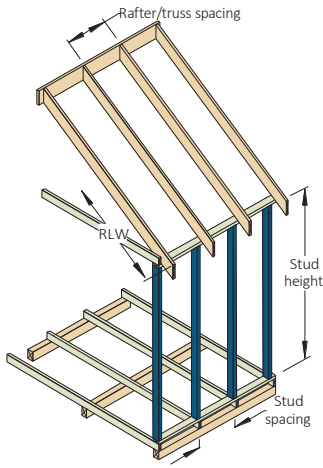

### EXAMPLE:

Sheet roof  
 Stud spacing = 450 mm  
 Rafter truss spacing = 600 mm  
 Stud height = 2700 mm  
 Roof load width = 6300 mm

Enter sheet roof column, 600 mm in rafter/truss spacing column, read down to a span roof load width of 6300 mm in a 2700 mm stud height.

### ADOPT:

Smart10 LVL - 2/70 x 35

Rafter/Truss spacing (mm)		450	600	900	1200	450	600	900	1200
Size DxB (mm)	Stud Height (mm)	Maximum recommended roof load width (mm)							
		Sheet Roof				Tile Roof			

### Stud spacing 450 mm

70x45	2400	4500	3500	2500	1500	3500	2500	2000	1500
	2700	1500	NS	NS	NS	NS	NS	NS	NS
	2400	7500	7500	7500	5500	7500	7500	5500	4500
2/70x35	2700	7500	6500	4000	3000	6500	5500	3500	2500
	3000	4500	3500	2200	1800	3500	2500	2000	1500
	2400	7500	7500	7500	7500	7500	7500	7500	6500
2/70x45	2700	7500	7500	6500	5000	7500	7500	5500	4000
	3000	7500	6500	4000	3000	6500	5000	3500	2500
	3600	2500	1500	NS	NS	1500	1500	NS	NS
	2400	7500	7500	5500	4500	7500	7500	4500	3500
90x35	2700	6500	4500	3000	2000	4500	3500	2500	2000
	3000	2500	1500	NS	NS	1500	1500	NS	NS
	2400	7500	7500	7500	7500	7500	7500	7500	5500
90x45	2700	7500	7500	5500	4500	7500	6500	4500	3500
	3000	6500	4500	3000	2500	5500	3500	2500	2000
	2700	7500	7500	7500	7500	7500	7500	7500	7500
2/90x35	3000	7500	7500	7500	6500	7500	7500	6500	5000
	3600	6500	5500	3500	2500	5500	4500	2500	1500
	3000	7500	7500	7500	7500	7500	7500	7500	7500
2/90x45	3600	7500	7500	5500	4500	7500	6500	4500	3500
	2700	7500	7500	7500	7500	7500	7500	7500	7500
	3000	7500	7500	7500	6500	7500	7500	7500	5500
120x35	3600	6500	4500	2500	2500	5500	3500	2500	1500
	3000	7500	7500	7500	7500	7500	7500	7500	7500
	3600	7500	7500	5500	4500	7500	7500	4500	3500
2/120x35	3600	7500	7500	7500	7500	7500	7500	7500	7500
	3600	7500	7500	7500	7500	7500	7500	7500	7500
	3600	7500	7500	7500	7500	7500	7500	7500	7500
2/120x45	3000	7500	7500	7500	7500	7500	7500	7500	7500
	3600	7500	7500	7500	5500	7500	7500	6500	4500
	3600	7500	7500	7500	7500	7500	7500	7500	7500
140x35	3600	7500	7500	7500	7500	7500	7500	7500	7500
	3600	7500	7500	7500	7500	7500	7500	7500	7500
	3600	7500	7500	7500	7500	7500	7500	7500	7500
140x45	3600	7500	7500	7500	7500	7500	7500	7500	7500
	3600	7500	7500	7500	7500	7500	7500	7500	7500
	3600	7500	7500	7500	7500	7500	7500	7500	7500
170x35	3600	7500	7500	7500	7500	7500	7500	7500	7500
	3600	7500	7500	7500	7500	7500	7500	7500	7500
	3600	7500	7500	7500	7500	7500	7500	7500	7500

### NOTES :

- D = member depth, B = member breadth, NS = not suitable
- The above table was based on a maximum wall mass of 37 kg/m<sup>2</sup>
- Multiple studs to be laminated as per AS 1684
- Stud not notched
- Maximum tension load in stud not to exceed 8.5 kN. Where studs are nailed laminated the tension load in each stud shall not exceed 8.5 kN.
- █ If design stud length (not gable end walls) is > 3000 mm, as a minimum, the DTS provisions within AS 1684 for the racking force (clause 8.3.4), fixing of bottom plate (clause 8.3.6.10), uplift and shear force provisions (clause 9.7.6 and Table 9.2) need to be modified to allow for the extra wall height - See page 4
- Not all sizes of SmartLVL in this table are stocked in each state. Please check with your supplier before ordering.



# Common Stud at 600 mm ctrs - Single/upper storey walls - Un-notched

## AS 4055 Classification C1 - C3

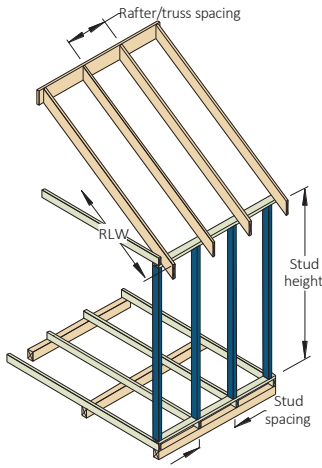

### EXAMPLE:

Sheet roof  
 Stud spacing = 600 mm  
 Rafter truss spacing = 600 mm  
 Stud height = 2700 mm  
 Roof load width = 6300 mm

Enter sheet roof column, 600 mm in rafter/truss spacing column, read down to a span roof load width of 6300 mm in a 2700 mm stud height.

### ADOPT:

Smart10 LVL - 2/70 x 35

Rafter/Truss spacing (mm)		450	600	900	1200	450	600	900	1200
Size DxB (mm)	Stud Height (mm)	Maximum recommended roof load width (mm)							
		Sheet Roof				Tile Roof			

### Stud spacing 600 mm

2/70x35	2400	7500	7500	5500	3500	6500	6500	4500	3500
	2700	3500	3500	2500	2000	3000	3000	2000	1500
2/70x45	2400	7500	7500	7500	6500	7500	7500	7500	5500
	2700	7500	7500	4500	3500	6500	6500	4000	3000
	3000	3500	3500	2500	2000	3500	3500	2000	1500
90x35	2400	5500	5500	3500	2500	4500	4500	2500	2000
90x45	2400	7500	7500	7500	5500	7500	7500	5500	4500
	2700	5500	5500	3500	2500	4500	4500	2500	2000
	3000	1500	1500	NS	NS	1500	1500	NS	NS
2/90x35	2400	7500	7500	7500	7500	7500	7500	7500	7500
	2700	7500	7500	7500	7500	7500	7500	7500	6500
	3000	7500	7500	6500	4500	7500	7500	5500	4000
	3600	2500	2500	1500	1500	2500	2500	1500	NS
2/90x45	2700	7500	7500	7500	7500	7500	7500	7500	7500
	3000	7500	7500	7500	7500	7500	7500	7500	6500
	3600	6500	6500	3500	2500	5500	5500	3500	2500
120x35	2400	7500	7500	7500	7500	7500	7500	7500	7500
	2700	7500	7500	7500	7500	7500	7500	7500	6500
	3000	7500	7500	5500	4500	7500	7500	4500	3500
120x45	2700	7500	7500	7500	7500	7500	7500	7500	7500
	3000	7500	7500	7500	7500	7500	7500	7500	6500
	3600	5500	5500	3500	2500	4500	4500	2500	1500
2/120x35	3000	7500	7500	7500	7500	7500	7500	7500	7500
	3600	7500	7500	7500	7500	7500	7500	7500	6500
2/120x45	3600	7500	7500	7500	7500	7500	7500	7500	7500
140x35	3000	7500	7500	7500	7500	7500	7500	7500	7500
	3600	7500	7500	4500	3500	6500	6500	3500	2500
140x45	3000	7500	7500	7500	7500	7500	7500	7500	7500
	3600	7500	7500	7500	6500	7500	7500	7500	5500
170x35	3600	7500	7500	7500	7500	7500	7500	7500	7500

### NOTES :

- D = member depth, B = member breadth, NS = not suitable
- The above table was based on a maximum wall mass of 37 kg/m<sup>2</sup>
- Multiple studs to be laminated as per AS 1684
- Stud not notched
- Maximum tension load in stud not to exceed 8.5 kN. Where studs are nailed laminated the tension load in each stud shall not exceed 8.5 kN.
- █ If design stud length (not gable end walls) is > 3000 mm, as a minimum, the DTS provisions within AS 1684 for the racking force (clause 8.3.4), fixing of bottom plate (clause 8.3.6.10), uplift and shear force provisions (clause 9.7.6 and Table 9.2) need to be modified to allow for the extra wall height - See page 4
- Not all sizes of SmartLVL in this table are stocked in each state. Please check with your supplier before ordering.

# Common Stud at 450 mm ctrs -Single/upper storey walls - 20 mm notched

## AS 4055 Classification N1- N4

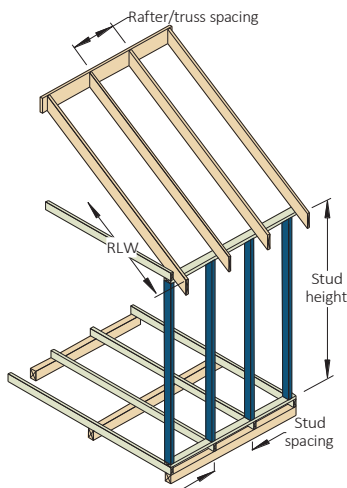

### EXAMPLE:

Sheet roof

Stud spacing = 450 mm

Rafter truss spacing = 600 mm

Stud height = 2700 mm

Roof load width = 6300

Enter sheet roof column, 600 mm in rafter/truss spacing column, read down to a span roof load width of 6300 mm in a 2700 mm stud height.

### ADOPT:

Smart10 LVL - 70 x 45

Rafter/truss spacing (mm)		450	600	900	1200	450	600	900	1200
Size DxB (mm)	Stud height (mm)	Maximum recommended roof load width (mm)							
		Sheet Roof				Tile Roof			
<b>Stud spacing 450 mm</b>									
70x35	2400	7500	7500	4500	3500	7500	5500	3500	2500
	2700	4500	3500	2500	2000	3500	2500	1500	NS
70x45	2400	7500	7500	7500	5500	7500	7500	5500	4000
	2700	7500	6500	4500	3000	6500	4500	3000	2200
	3000	4500	3500	1500	1500	2500	2500	1500	NS
2/70x35	2400	7500	7500	7500	7500	7500	7500	7500	7500
	2700	7500	7500	7500	6500	7500	7500	6500	4500
	3000	7500	7500	5500	4500	7500	5500	4000	3000
2/70x45	2400	7500	7500	7500	7500	7500	7500	7500	7500
	2700	7500	7500	7500	7500	7500	7500	7500	6500
	3000	7500	7500	7500	6500	7500	7500	5500	4500
90x35	2400	7500	7500	7500	7500	7500	7500	7500	7500
	2700	7500	7500	7500	6500	7500	7500	6500	4500
	3000	7500	7500	5500	4000	7500	5500	3500	3000
90x45	2700	7500	7500	7500	7500	7500	7500	7500	7500
	3000	7500	7500	7500	6500	7500	7500	5500	4500
	3600	7500	7500	7500	5500	7500	7500	5500	3500
2/90x35	3000	7500	7500	7500	7500	7500	7500	7500	7500
	3600	7500	7500	7500	5500	7500	7500	5500	3500
2/90x45	3000	7500	7500	7500	7500	7500	7500	7500	7500
	3600	7500	7500	7500	7500	7500	7500	7500	5500
120x35	3000	7500	7500	7500	7500	7500	7500	7500	7500
	3600	7500	7500	7500	5500	7500	7500	5500	4500
120x45	3000	7500	7500	7500	7500	7500	7500	7500	7500
	3600	7500	7500	7500	7500	7500	7500	7500	6500
140x35	3600	7500	7500	7500	7500	7500	7500	7500	7500
140x45	3600	7500	7500	7500	7500	7500	7500	7500	7500
170x35	3600	7500	7500	7500	7500	7500	7500	7500	7500

### NOTES :

1. D = member depth, B = member breadth, NS = not suitable
2. The above table was based on a maximum wall mass of 37 kg/m<sup>2</sup>
3. Multiple studs to be laminated as per AS 1684
4. Stud not notched
5. Maximum tension load in stud not to exceed 8.5 kN. Where studs are nailed laminated the tension load in each stud shall not exceed 8.5 kN.
6. If design stud length (not gable end walls) is > 3000 mm, as a minimum, the DTS provisions within AS 1684 for the racking force (clause 8.3.4), fixing of bottom plate (clause 8.3.6.10), uplift and shear force provisions (clause 9.7.6 and Table 9.2) need to be modified to allow for the extra wall height - See page 4
7. Not all sizes of SmartLVL in this table are stocked in each state. Please check with your supplier before ordering.

# Common Stud at 600 mm ctrs -Single/upper storey walls - 20 mm notched AS 4055 Classification N1- N4

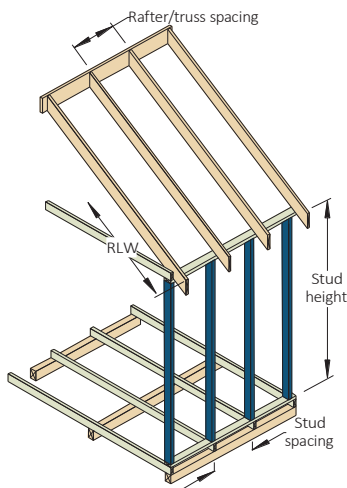

## EXAMPLE:

Sheet roof

Stud spacing = 600 mm

Rafter truss spacing = 600 mm

Stud height = 2700 mm

Roof load width = 6300

Enter roof column, 600 mm in rafter/truss spacing column, read down to a span roof load width of 6300 mm in a 2700 mm stud height.

## ADOPT:

Smart10 LVL - 2/70 x 35

Rafter/truss spacing (mm)		450	600	900	1200	450	600	900	1200
Size DxB (mm)	Stud height (mm)	Maximum recommended roof load width (mm)							
		Sheet Roof				Tile Roof			
<b>Stud spacing 600 mm</b>									
70x35	2400	5500	5500	3500	2500	3500	3500	2500	2000
70x45	2400	7500	7500	6500	4500	6500	6500	4500	3500
	2700	4500	4500	2500	2000	3000	3000	2000	1500
2/70x35	2400	7500	7500	7500	7500	7500	7500	7500	6500
	2700	7500	7500	7500	5500	7500	7500	5500	4000
	3000	6500	6500	4500	3500	4500	4500	3000	2500
2/70x45	2400	7500	7500	7500	7500	7500	7500	7500	7500
	2700	7500	7500	7500	7500	7500	7500	7500	5500
	3000	7500	7500	6500	5500	7500	7500	5000	3500
90x35	2400	7500	7500	7500	7500	7500	7500	7500	6500
	2700	7500	7500	7500	5500	7500	7500	5500	3500
	3000	5500	5500	3500	2500	3500	3500	2500	2000
90x45	2400	7500	7500	7500	7500	7500	7500	7500	7500
	2700	7500	7500	7500	7500	7500	7500	7500	6500
	3000	7500	7500	6500	4500	7500	7500	4500	3500
2/90x35	3000	7500	7500	7500	7500	7500	7500	7500	7500
2/90x45	3000	7500	7500	7500	7500	7500	7500	7500	7500
	3600	7500	7500	7500	6500	7500	7500	6500	4500
120x35	3000	7500	7500	7500	7500	7500	7500	7500	7500
	3600	7500	7500	5500	4500	5500	5500	3500	2500
120x45	3000	7500	7500	7500	7500	7500	7500	7500	7500
	3600	7500	7500	7500	7500	7500	7500	7500	5500
2/120x35	3600	7500	7500	7500	7500	7500	7500	7500	7500
2/120x45	3600	7500	7500	7500	7500	7500	7500	7500	7500
140x35	3600	7500	7500	7500	7500	7500	7500	7500	7500
140x45	3600	7500	7500	7500	7500	7500	7500	7500	7500
2/140x35	3600	7500	7500	7500	7500	7500	7500	7500	7500
2/140x45	3600	7500	7500	7500	7500	7500	7500	7500	7500
170x35	3600	7500	7500	7500	7500	7500	7500	7500	7500

## NOTES :

1. D = member depth, B = member breadth, NS = not suitable
2. The above table was based on a maximum wall mass of 37 kg/m<sup>2</sup>
3. Multiple studs to be laminated as per AS 1684
4. Stud not notched
5. Maximum tension load in stud not to exceed 8.5 kN. Where studs are nailed laminated the tension load in each stud shall not exceed 8.5 kN.
6. If design stud length (not gable end walls) is > 3000 mm, as a minimum, the DTS provisions within AS 1684 for the racking force (clause 8.3.4), fixing of bottom plate (clause 8.3.6.10), uplift and shear force provisions (clause 9.7.6 and Table 9.2) need to be modified to allow for the extra wall height - See page 4
7. Not all sizes of SmartLVL in this table are stocked in each state. Please check with your supplier before ordering.

# Common Stud 450 ctrs - Single/upper storey walls - 20 mm notched

## AS 4055 Classification C1 – C3

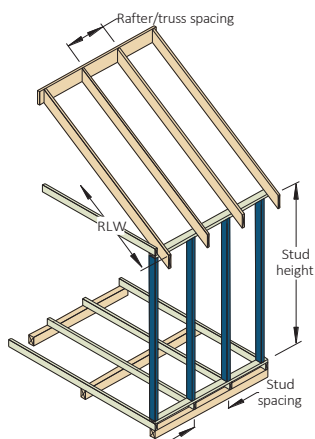

### EXAMPLE:

Sheet roof

Stud spacing = 450 mm

Rafter truss spacing = 600 mm

Stud height = 2700 mm

Roof load width = 6500 mm

Enter sheet roof column, 600 mm in rafter/truss spacing column, read down to a span roof load width of 6500 mm in a 2700 mm stud height.

### ADOPT:

Smart10 LVL - 2/70 x 45

Rafter/truss spacing (mm)		450	600	900	1200	450	600	900	1200
Size Dx B (mm)	Stud height (mm)	Maximum recommended roof load width (mm)							
		Sheet Roof				Tile Roof			
<b>Stud spacing 450 mm</b>									
70x35	2400	1500	NS	NS	NS	1500	NS	NS	NS
70x45	2400	4500	3500	2000	1500	3500	2500	1500	NS
2/70x35	2400	7500	7500	5500	4500	7500	7500	4500	3500
	2700	6500	4500	3000	2500	5500	3500	2500	2000
	3000	2500	1500	NS	NS	1500	1500	NS	NS
2/70x45	2400	7500	7500	7500	6500	7500	7500	7500	5500
	2700	7500	7500	4500	3500	7500	6500	4000	3000
	3000	5500	3500	2500	2000	4500	3500	2000	1500
90x35	2400	7500	7500	5500	3500	7500	6500	4500	3500
	2700	4500	3500	2500	1500	3500	2500	1500	1500
90x45	2400	7500	7500	7500	6500	7500	7500	7500	5500
	2700	7500	6500	4500	3500	7500	5500	3500	2500
	3000	3500	2500	1500	1500	3500	2500	1500	NS
2/90x35	2400	7500	7500	7500	7500	7500	7500	7500	7500
	2700	7500	7500	7500	7500	7500	7500	7500	6500
	3000	7500	7500	6500	4500	7500	7500	5500	4000
2/90x45	2700	7500	7500	7500	7500	7500	7500	7500	7500
	3000	7500	7500	7500	7500	7500	7500	7500	5500
	3600	6500	5500	3500	2500	5500	4500	2500	1500
120x35	2700	7500	7500	7500	7500	7500	7500	7500	7500
	3000	7500	7500	6500	4500	7500	7500	5500	4500
	3600	1500	NS	NS	NS	NS	NS	NS	NS
120x45	2700	7500	7500	7500	7500	7500	7500	7500	7500
	3000	7500	7500	7500	7500	7500	7500	7500	6500
	3600	6500	4500	2500	2500	5500	3500	2500	1500
2/120x35	3000	7500	7500	7500	7500	7500	7500	7500	7500
	3600	7500	7500	7500	7500	7500	7500	7500	5500
2/120x45	3600	7500	7500	7500	7500	7500	7500	7500	7500
140x35	3000	7500	7500	7500	7500	7500	7500	7500	7500
	3600	7500	6500	4500	3500	7500	5500	3500	2500
140x45	3000	7500	7500	7500	7500	7500	7500	7500	7500
	3600	7500	7500	7500	6500	7500	7500	6500	5500
170x35	3600	7500	7500	7500	7500	7500	7500	7500	7500

### NOTES :

- D = member depth, B = member breadth, NS = not suitable
- The above table was based on a maximum wall mass of 37 kg/m<sup>2</sup>
- Multiple studs to be laminated as per AS 1684
- Stud not notched
- Maximum tension load in stud not to exceed 8.5 kN. Where studs are nailed laminated the tension load in each stud shall not exceed 8.5 kN.
- If design stud length (not gable end walls) is > 3000 mm, as a minimum, the DTS provisions within AS 1684 for the racking force (clause 8.3.4), fixing of bottom plate (clause 8.3.6.10), uplift and shear force provisions (clause 9.7.6 and Table 9.2) need to be modified to allow for the extra wall height - See page 4
- Not all sizes of SmartLVL in this table are stocked in each state. Please check with your supplier before ordering.



# Common Stud at 600 mm ctrs - Single/upper storey walls - 20 mm notched

## AS 4055 Classification C1 – C3

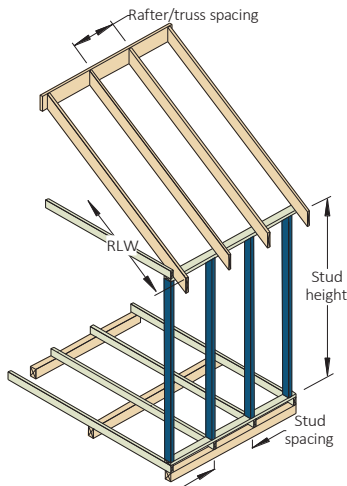

### EXAMPLE:

Sheet roof

Stud spacing = 450 mm

Rafter truss spacing = 600 mm

Stud height = 2700 mm

Roof load width = 6500 mm

Enter sheet roof column, 600 mm in rafter/truss spacing column, read down to a span roof load width of 6500 mm in a 2700 mm stud height.

### ADOPT:

Smart10 LVL - 2/90 x 35

Rafter/truss spacing (mm)		450	600	900	1200	450	600	900	1200
Size Dx B (mm)	Stud height (mm)	Maximum recommended roof load width (mm)							
		Sheet Roof				Tile Roof			
<b>Stud spacing 600 mm</b>									
2/70x35	2400	6500	6500	4500	3500	5500	5500	3500	2500
	2700	2500	2500	1500	1500	2500	2500	1500	NS
2/70x45	2400	7500	7500	7500	5500	7500	7500	5500	4500
	2700	5500	5500	3500	2500	4500	4500	3000	2500
	3000	1500	1500	1500	NS	1500	1500	NS	NS
90x35	2400	5500	5500	3500	2500	4500	4500	2500	2000
	2700	7500	7500	6500	4500	7500	7500	5500	3500
90x45	2400	7500	7500	6500	4500	7500	7500	5500	3500
	2700	3500	3500	2500	1500	3500	3500	2000	1500
2/90x35	2400	7500	7500	7500	7500	7500	7500	7500	7500
	2700	7500	7500	7500	6500	7500	7500	7500	5500
	3000	6500	6500	4500	3500	5500	5500	3500	2500
2/90x45	2700	7500	7500	7500	7500	7500	7500	7500	7500
	3000	7500	7500	7500	5500	7500	7500	6500	4500
120x35	2400	7500	7500	7500	7500	7500	7500	7500	7500
	2700	7500	7500	7500	6500	7500	7500	7500	5500
	3000	6500	6500	3500	2500	4500	4500	3500	2500
120x45	2700	7500	7500	7500	7500	7500	7500	7500	7500
	3000	7500	7500	7500	6500	7500	7500	6500	4500
2/120x35	3000	7500	7500	7500	7500	7500	7500	7500	7500
	3600	7500	7500	7500	5500	7500	7500	5500	4500
2/120x45	3600	7500	7500	7500	7500	7500	7500	7500	7500
140x35	2700	7500	7500	7500	7500	7500	7500	7500	7500
	3000	7500	7500	7500	7500	7500	7500	7500	6500
	3600	1500	1500	1500	NS	1500	1500	NS	NS
140x45	3000	7500	7500	7500	7500	7500	7500	7500	7500
	3600	7500	7500	5500	3500	6500	6500	4500	2500
170x35	3000	7500	7500	7500	7500	7500	7500	7500	7500
	3600	7500	7500	7500	7500	7500	7500	7500	5500

### NOTES :

1. D = member depth, B = member breadth, NS = not suitable
2. The above table was based on a maximum wall mass of 37 kg/m<sup>2</sup>
3. Multiple studs to be laminated as per AS 1684
4. Stud not notched
5. Maximum tension load in stud not to exceed 8.5 kN. Where studs are nailed laminated the tension load in each stud shall not exceed 8.5 kN.
6. If design stud length (not gable end walls) is > 3000 mm, as a minimum, the DTS provisions within AS 1684 for the racking force (clause 8.3.4), fixing of bottom plate (clause 8.3.6.10), uplift and shear provisions (clause 9.7.6 and Table 9.2) need to be modified to allow for the extra wall height - See page 4
7. Not all sizes of SmartLVL in this table are stocked in each state. Please check with your supplier before ordering.

# Jamb Stud - Single of upper load bearing walls

## AS 4055 Classification N1-N4

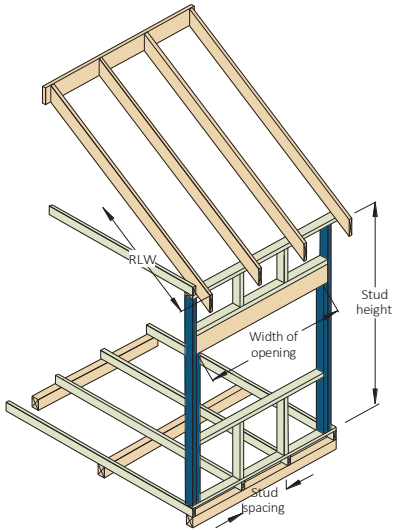

**EXAMPLE:**

Sheet roof

Width of opening = 1800 mm

Jamb stud height = 2700 mm

Roof load width = 4100 mm

Enter table at 4500 mm roof load width, sheet roof column, read down to a width of opening of 1800 mm in a 2700 mm stud height row with a roof mass of 40 kg/m<sup>2</sup>.

**ADOPT:**

**Smart10 LVL - 2/70 x 45**

Roof load width (mm)		1500	3000	4500	6000	7500	1500	3000	4500	6000	7500
Size DxB (mm)	Stud height (mm)	Sheet roof					Tile roof				
		Width of opening (mm)					Width of opening (mm)				
70x45	2400	900	900	900	NS	NS	900	900	NS	NS	NS
	2700	2100	2100	1800	1500	1400	2100	2100	1600	1400	1100
2/70x35	2400	1200	1200	1100	1000	1000	1200	1200	1100	900	NS
	2700	2700	2700	2500	2000	1800	2700	2700	2200	1700	1400
	3000	1800	1800	1800	1400	1400	1800	1800	1600	1300	1000
2/70x45	2400	900	900	900	900	900	900	900	900	900	NS
	2700	2200	2000	1600	1400	1200	2200	1800	1500	1200	900
	3000	1400	1400	1200	1000	NS	1400	1300	1000	NS	NS
90x35	2400	3200	2700	2200	1800	1700	3200	2500	1800	1500	1400
	2700	1800	1800	1600	1400	1300	1800	1800	1400	1200	900
	3000	1100	1100	1100	1000	900	1100	1100	1000	NS	NS
90x45	2400	4500	4500	4000	3300	2700	4500	4500	3400	2700	2300
	2700	3600	3600	3200	2500	2200	3600	3300	2700	2200	1800
	3000	2200	2200	2200	2000	1600	2200	2200	2000	1600	1500
2/90x35	2400	4500	4500	4500	4500	3600	4500	4500	4500	3600	3000
	2700	4500	4500	4000	3400	2900	4500	4500	3600	2900	2300
	3000	3200	3200	3000	2700	2300	3200	3200	2700	2300	1800
	3600	900	900	900	900	900	900	900	900	900	900
2/90x45	2400	4500	4500	3900	3300	2700	4500	4000	3300	2700	2500
	2700	4500	3600	3000	2500	2200	4000	3200	2500	2200	1800
	3000	2700	2700	2300	2000	1700	2700	2500	2000	1700	1500
	3600	900	900	900	900	900	900	900	900	900	NS
120x35	2400	4500	4500	4500	4200	3600	4500	4500	4500	3600	3300
	2700	4500	4500	3900	3400	2900	4500	4200	3400	2900	2500
	3000	4000	3600	3200	2700	2300	4000	3300	2700	2300	2000
	3600	900	900	900	900	900	900	900	900	900	900
120x45	2400	4500	4500	4500	4500	4500	4500	4500	4500	4500	4500
	2700	4500	4500	4500	4500	4500	4500	4500	4500	4500	4200
	3000	4500	4500	4500	4500	3900	4500	4500	4500	3900	3400
	3600	2700	2700	2700	2700	2700	2700	2700	2700	2700	1800
2/120x35	3000	4500	4500	4500	4500	4500	4500	4500	4500	4500	4500
	3600	3600	3600	3600	3600	3600	3600	3600	3600	3600	2700
2/120x45	2400	4500	4500	4500	4500	4500	4500	4500	4500	4500	3900
	2700	4500	4500	4500	3900	3400	4500	4500	4000	3400	3000
	3000	4500	4200	3600	3200	2700	4500	3900	3200	2700	2300
	3600	1800	1800	1800	1800	900	1800	1800	1800	900	900

## Jamb Stud—Single of upper load bearing walls AS 4055 Classification N1-N4

Roof load width (mm)		1500	3000	4500	6000	7500	1500	3000	4500	6000	7500
Size Dx B (mm)	Stud height (mm)	Sheet roof					Tile roof				
		Width of opening (mm)					Width of opening (mm)				
140x45	2400	4500	4500	4500	4500	4500	4500	4500	4500	4500	4500
	2700	4500	4500	4500	4500	4500	4500	4500	4500	4500	3900
	3000	4500	4500	4500	4200	3600	4500	4500	4200	3600	3200
	3600	2700	2700	2700	2700	1800	2700	2700	2700	1800	1800
2/140x35	3000	4500	4500	4500	4500	4500	4500	4500	4500	4500	4500
	3600	4500	4500	4500	4500	3600	4500	4500	4500	3600	3600
2/140x45	3600	4500	4500	4500	4500	4500	4500	4500	4500	4500	4500
170x35	2700	4500	4500	4500	4500	4500	4500	4500	4500	4500	4500
	3000	4500	4500	4500	4500	4500	4500	4500	4500	4500	4200
	3600	4500	4500	3600	2700	2700	4500	3600	3600	2700	2700
170x45	3000	4500	4500	4500	4500	4500	4500	4500	4500	4500	4500
	3600	4500	4500	4500	4500	3600	4500	4500	4500	3600	3600
2/170x35	3600	4500	4500	4500	4500	4500	4500	4500	4500	4500	4500
2/170x45	3600	4500	4500	4500	4500	4500	4500	4500	4500	4500	4500

### NOTES :

1. D = member depth, B = member breadth, NS = not suitable
2. The above table was based on a maximum wall mass of 37 kg/m<sup>2</sup>
3. Multiple studs to be laminated as per AS 1684
4. Stud not notched
5. Maximum tension load in stud not to exceed 8.5 kN. Where studs are nailed laminated the tension load in each stud shall not exceed 8.5 kN.
6. ■■■ If design stud length (not gable end walls) is > 3000 mm, as a minimum, the DTS provisions within AS 1684 for the racking force (clause 8.3.4), fixing of bottom plate (clause 8.3.6.10), uplift and shear force provisions (clause 9.7.6 and Table 9.2) need to be modified to allow for the extra wall height - See page 4
7. Not all sizes of SmartLVL in this table are stocked in each state. Please check with your supplier before ordering.

# Jamb Stud - Single of upper load bearing walls

## AS 4055 Classification C1-C3

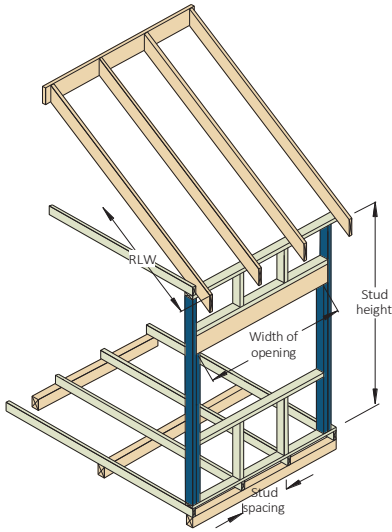

**EXAMPLE:**

Sheet roof

Width of opening = 1800 mm

Jamb stud height = 2700 mm

Roof load width = 4100 mm

Enter table at 4500 mm roof load width, sheet roof column, read down to a width of opening of 1800 mm in a 2700 mm stud height row with a roof mass of 40 kg/m<sup>2</sup>.

**ADOPT:**

**Smart10 LVL - 2/90 x 45**

Roof load width (mm)		1500	3000	4500	6000	7500	1500	3000	4500	6000	7500
Size DxB (mm)	Stud height (mm)	Sheet roof					Tile roof				
		Width of opening (mm)					Width of opening (mm)				
2/70x45 90x45	2400	900	900	900	900	NS	900	900	900	NS	NS
	2400	1200	1100	900	NS	NS	1200	1100	NS	NS	NS
2/90x35	2400	2200	2100	1800	1500	1400	2200	2100	1600	1400	1200
	2700	1400	1400	1300	1200	1000	1400	1400	1200	1000	NS
2/90x45	2400	3200	3000	2500	2000	1800	3200	3000	2200	1800	1700
	2700	2100	2100	1800	1500	1400	2100	2100	1600	1400	1300
	3000	1200	1200	1100	1000	1000	1200	1200	1100	1000	900
120x35	2400	2500	2000	1700	1500	1400	2500	2000	1600	1400	1200
	2700	1800	1400	1300	1200	900	1800	1400	1200	1000	NS
	3000	900	900	900	NS	NS	900	900	NS	NS	NS
120x45	2400	3600	2700	2300	2000	1800	3300	2700	2200	1800	1700
	2700	2400	2200	1800	1500	1400	2400	2000	1600	1400	1300
	3000	1500	1500	1300	1200	1000	1500	1400	1200	1000	900
2/120x35	2400	4500	4500	4200	3600	3000	4500	4500	3900	3300	2700
	2700	4500	3900	3300	2700	2300	4500	3600	3000	2500	2200
	3000	2700	2700	2500	2200	1800	2700	2700	2300	2000	1700
	3600	900	900	900	900	900	900	900	900	900	900
2/120x45	2400	4500	4500	4500	4500	4000	4500	4500	4500	4500	3600
	2700	4500	4500	4200	3600	3200	4500	4500	4000	3400	2900
	3000	4000	4000	3300	2900	2600	4000	3900	3200	2700	2300
	3600	900	900	900	900	900	900	900	900	900	900
140x35	2400	3900	3300	2700	2300	2000	3600	3000	2500	2200	1800
	2700	3000	2500	2000	1800	1600	2900	2300	1800	1700	1500
	3000	2100	1800	1500	1400	1200	2100	1800	1400	1300	1100
140x45	2400	4500	4200	3600	3000	2700	4500	4000	3300	2900	2500
	2700	4000	3300	2700	2300	2200	3900	3200	2500	2200	2000
	3000	3000	2500	2200	1800	1700	3000	2500	2000	1700	1600
	3600	900	900	900	900	900	900	900	900	900	900
2/140x35	2400	4500	4500	4500	4500	4500	4500	4500	4500	4500	4500
	2700	4500	4500	4500	4200	3600	4500	4500	4500	3900	3400
	3000	4500	4500	3900	3400	2900	4500	4500	3600	3200	2700
	3600	1800	1800	1800	1800	1800	1800	1800	1800	1800	1800
2/140x45	2700	4500	4500	4500	4500	4500	4500	4500	4500	4500	4500
	3000	4500	4500	4500	4500	3900	4500	4500	4500	4200	3600
	3600	2700	2700	2700	2700	1800	2700	2700	2700	2700	1800

## Jamb Stud—Single of upper load bearing walls AS 4055 Classification N1-N4

Roof load width (mm)		1500	3000	4500	6000	7500	1500	3000	4500	6000	7500
Size DxB (mm)	Stud height (mm)	Sheet roof					Tile roof				
		Width of opening (mm)					Width of opening (mm)				
170x35	2400	4500	4500	4200	3900	3400	4500	4500	4200	3600	3200
	2700	4500	4000	3400	3000	2700	4500	3900	3300	2900	2500
	3000	3900	3200	2700	2400	2200	3600	3200	2600	2300	2000
	3600	1800	1800	1800	900	900	1800	1800	900	900	900

### NOTES :

1. D = member depth, B = member breadth, NS = not suitable
2. The above table was based on a maximum wall mass of 37 kg/m<sup>2</sup>
3. Multiple studs to be laminated as per AS 1684
4. Stud not notched
5. Maximum tension load in stud not to exceed 8.5 kN. Where studs are nailed laminated the tension load in each stud shall not exceed 8.5 kN.
6. ■ If design stud length (not gable end walls) is > 3000 mm, as a minimum, the DTS provisions within AS 1684 for the racking force (clause 8.3.4), fixing of bottom plate (clause 8.3.6.10), uplift and shear force provisions (clause 9.7.6 and Table 9.2) need to be modified to allow for the extra wall height - See page 4
7. Not all sizes of SmartLVL in this table are stocked in each state. Please check with your supplier before ordering.



# Wall studs - lower storey load bearing walls - Non notched

## AS 4055 classification N1 - N4

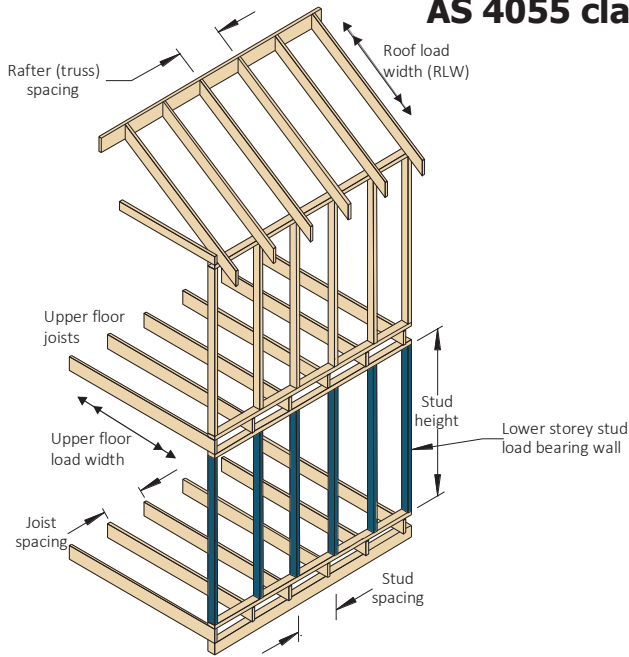

### EXAMPLE:

- Un - notched stud
- Stud spacing = 450 mm
- Floor joist spacing = 600 mm
- Stud height = 3000 mm
- Floor load width = 4100 mm
- Roof load width = 7500 mm

Enter table at 450 mm stud spacing column, 600 mm joist spacing column, 4800 floor load width column, read down to a roof load width of 7500 mm in a 3000 mm stud height row.

### ADOPT:

Smart10 LVL - 90x45

Sheet roof 40 kg/m <sup>2</sup>													
Stud spacing (mm)		450						600					
Floor joist spacing (mm)		450			600			450			600		
Upper floor load width (mm)		1800	3600	4800	1800	3600	4800	1800	3600	4800	1800	3600	4800
Size Dx8 (mm)	Stud height (mm)	Roof load width (RLW) (mm)											
70x35	2400	7500	7500	7500	7500	7500	7500	7500	7500	7500	7500	7500	7500
	2700	7500	7500	7500	7500	6500	5500	6500	4500	3500	6500	4500	3500
	3000	6500	4500	3500	4500	2500	NS	NS	NS	NS	NS	NS	NS
70x45	2700	7500	7500	7500	7500	7500	7500	7500	7500	7500	7500	7500	7500
	3000	7500	7500	7500	7500	5500	4500	NS	NS	NS	NS	NS	NS
2/70x35	3000	7500	7500	7500	7500	7500	7500	7500	7500	7500	7500	7500	7500
2/70x45	3000	7500	7500	7500	7500	7500	7500	7500	7500	7500	7500	7500	7500
90x35	3000	7500	7500	7500	7500	7500	7500	7500	7500	7500	7500	7500	7500
90x45	3000	7500	7500	7500	7500	7500	7500	7500	7500	7500	7500	7500	7500
2/90x35	3000	7500	7500	7500	7500	7500	7500	7500	7500	7500	7500	7500	7500
2/90x45	3000	7500	7500	7500	7500	7500	7500	7500	7500	7500	7500	7500	7500
120x35	3000	7500	7500	7500	7500	7500	7500	7500	7500	7500	7500	7500	7500
120x45	3000	7500	7500	7500	7500	7500	7500	7500	7500	7500	7500	7500	7500
2/120x35	3000	7500	7500	7500	7500	7500	7500	7500	7500	7500	7500	7500	7500
2/120x45	3000	7500	7500	7500	7500	7500	7500	7500	7500	7500	7500	7500	7500
140x35	3000	7500	7500	7500	7500	7500	7500	7500	7500	7500	7500	7500	7500
140x45	3000	7500	7500	7500	7500	7500	7500	7500	7500	7500	7500	7500	7500
2/140x35	3000	7500	7500	7500	7500	7500	7500	7500	7500	7500	7500	7500	7500
2/140x45	3000	7500	7500	7500	7500	7500	7500	7500	7500	7500	7500	7500	7500
170x35	3000	7500	7500	7500	7500	7500	7500	7500	7500	7500	7500	7500	7500
Tiled roof 90 kg/m <sup>2</sup>													
70x35	2400	7500	7500	7500	7500	7500	6500	7500	7500	6500	7500	7500	6500
	2700	7500	6500	5500	5500	4500	2500	4500	3500	2500	4500	3500	2500
	3000	4500	2500	2500	2500	1500	NS	NS	NS	NS	NS	NS	NS
70x45	2400	7500	7500	7500	7500	7500	7500	7500	7500	7500	7500	7500	7500
	2700	7500	7500	7500	7500	6500	5500	7500	6500	5500	7500	6500	5500
	3000	7500	5500	4500	5500	3500	2500	NS	NS	NS	NS	NS	NS
2/70x35	2700	7500	7500	7500	7500	7500	7500	7500	7500	7500	7500	7500	7500
	3000	7500	7500	7500	7500	7500	7500	7500	7500	6500	7500	7500	6500
2/70x45	3000	7500	7500	7500	7500	7500	7500	7500	7500	7500	7500	7500	7500
90x35	3000	7500	7500	7500	7500	7500	7500	7500	7500	7500	7500	7500	7500
90x45	3000	7500	7500	7500	7500	7500	7500	7500	7500	7500	7500	7500	7500

## Wall studs - lower storey load bearing walls - Non notched AS 4055 classification N1 - N4

Tile roof 90 kg/m <sup>2</sup>													
Stud spacing (mm)		450						600					
Floor joist spacing (mm)		450			600			450			600		
Upper floor load width (mm)		1800	3600	4800	1800	3600	4800	1800	3600	4800	1800	3600	4800
Size DxB (mm)	Stud height (mm)	Roof load width (RLW) (mm)											
2/90x35	3000	7500	7500	7500	7500	7500	7500	7500	7500	7500	7500	7500	7500
2/90x45	3000	7500	7500	7500	7500	7500	7500	7500	7500	7500	7500	7500	7500
120x35	3000	7500	7500	7500	7500	7500	7500	7500	7500	7500	7500	7500	7500
120x45	3000	7500	7500	7500	7500	7500	7500	7500	7500	7500	7500	7500	7500
2/120x35	3000	7500	7500	7500	7500	7500	7500	7500	7500	7500	7500	7500	7500
2/120x45	3000	7500	7500	7500	7500	7500	7500	7500	7500	7500	7500	7500	7500
140x35	3000	7500	7500	7500	7500	7500	7500	7500	7500	7500	7500	7500	7500
140x45	3000	7500	7500	7500	7500	7500	7500	7500	7500	7500	7500	7500	7500
2/140x35	3000	7500	7500	7500	7500	7500	7500	7500	7500	7500	7500	7500	7500
2/140x45	3000	7500	7500	7500	7500	7500	7500	7500	7500	7500	7500	7500	7500
170x35	3000	7500	7500	7500	7500	7500	7500	7500	7500	7500	7500	7500	7500

### NOTES :

1. D = member depth, B = member breadth, NS = not suitable.
2. Total upper floor mass of 40 kg/m<sup>2</sup>, total wall mass of 37 kg/m<sup>2</sup>, floor live load of 1.5 kPa
3. Stud not notched. Maximum tension load in stud not to exceed 8.5 kN.
4. Where studs are nailed laminated the tension load in each stud shall not exceed 8.5 kN.
5. **Not all sizes of SmartLVL in this table are stocked in each state. Please check with your supplier before ordering**

# Wall studs - lower storey load bearing walls - Non notched

## AS 4055 classification C1 - C3

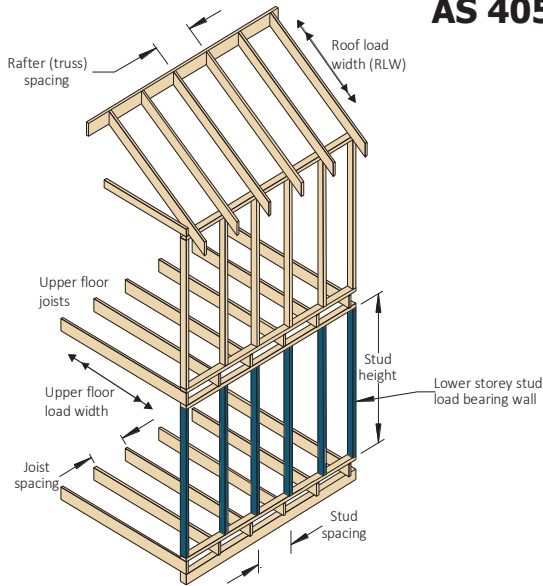

**EXAMPLE:**

- Un - notched stud
- Stud spacing = 450 mm
- Floor joist spacing = 600 mm
- Stud height = 3000 mm
- Floor load width = 4100 mm
- Roof load width =

Enter table at 450 mm stud spacing column, 600 mm joist spacing column, 4800 mm floor load width, read down to a roof load width of 7500 mm in a 3000 mm stud height row.

**ADOPT:**

Smart10 LVL - 2/70 x 35

Sheet roof 40 kg/m <sup>2</sup>													
Stud spacing (mm)		450						600					
Floor joist spacing (mm)		450			600			450			600		
Upper floor load width (mm)		1800	3600	4800	1800	3600	4800	1800	3600	4800	1800	3600	4800
Size Dx B (mm)	Stud height (mm)	Roof load width (RLW) (mm)											
70x35	2400	7500	7500	6500	5500	4500	4500	3500	3500	2500	3500	3500	2500
	2700	3500	2500	1500	2500	1500	NS	NS	NS	NS	NS	NS	NS
70x45	2400	7500	7500	7500	7500	7500	7500	7500	6500	5500	7500	6500	5500
	2700	6500	5500	5500	4500	3500	3500	2500	2500	1500	2500	2500	1500
2/70x35	2700	7500	7500	7500	7500	7500	7500	7500	7500	7500	7500	7500	7500
	3000	7500	7500	7500	6500	5500	5500	5500	4500	3500	5500	4500	3500
2/70x45	3000	7500	7500	7500	7500	7500	7500	7500	7500	7500	7500	7500	7500
	2400	7500	7500	7500	7500	7500	7500	7500	7500	7500	7500	7500	7500
90x35	2700	7500	7500	7500	7500	7500	7500	7500	7500	6500	7500	7500	6500
	3000	7500	7500	6500	5500	4500	4500	3500	2500	1500	3500	2500	1500
	2400	7500	7500	7500	7500	7500	7500	7500	7500	7500	7500	7500	7500
90x45	2700	7500	7500	7500	7500	7500	7500	7500	7500	7500	7500	7500	7500
	3000	7500	7500	7500	7500	7500	7500	7500	6500	5500	7500	6500	5500
2/90x35	3000	7500	7500	7500	7500	7500	7500	7500	7500	7500	7500	7500	7500
	3000	7500	7500	7500	7500	7500	7500	7500	7500	7500	7500	7500	7500
120x35	3000	7500	7500	7500	7500	7500	7500	7500	7500	7500	7500	7500	7500
	3000	7500	7500	7500	7500	7500	7500	7500	7500	7500	7500	7500	7500
2/120x35	3000	7500	7500	7500	7500	7500	7500	7500	7500	7500	7500	7500	7500
	3000	7500	7500	7500	7500	7500	7500	7500	7500	7500	7500	7500	7500
140x35	3000	7500	7500	7500	7500	7500	7500	7500	7500	7500	7500	7500	7500
	3000	7500	7500	7500	7500	7500	7500	7500	7500	7500	7500	7500	7500
2/140x35	3000	7500	7500	7500	7500	7500	7500	7500	7500	7500	7500	7500	7500
	3000	7500	7500	7500	7500	7500	7500	7500	7500	7500	7500	7500	7500
2/140x45	3000	7500	7500	7500	7500	7500	7500	7500	7500	7500	7500	7500	7500
	3000	7500	7500	7500	7500	7500	7500	7500	7500	7500	7500	7500	7500
170x35	3000	7500	7500	7500	7500	7500	7500	7500	7500	7500	7500	7500	7500
	3000	7500	7500	7500	7500	7500	7500	7500	7500	7500	7500	7500	7500

**NOTES :**

1. D = member depth, B = member breadth, NS = not suitable.
2. Total upper floor mass of 40 kg/m<sup>2</sup>, total wall mass of 37 kg/m<sup>2</sup>, floor live load of 1.5 kPa
3. Stud not notched. Maximum tension load in stud not to exceed 8.5 kN.
4. Where studs are nailed laminated the tension load in each stud shall not exceed 8.5 kN.
5. **Not all sizes of SmartLVL in this table are stocked in each state. Please check with your supplier before ordering**

# Wall studs - lower storey load bearing walls - Non notched

## AS 4055 classification C1 - C3

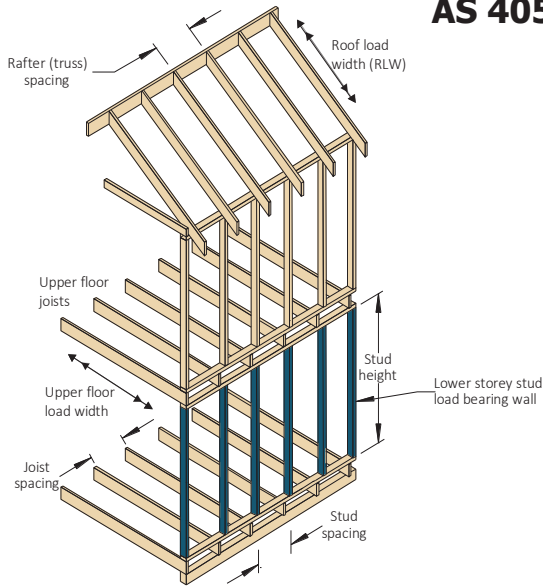

**EXAMPLE:**

- Un - notched stud
- Stud spacing = 450 mm
- Floor joist spacing = 600 mm
- Stud height = 3000 mm
- Floor load width = 4100 mm
- Roof load width =

Enter table at 450 mm stud spacing column, 600 mm joist spacing column, 4800 mm floor load width, read down to a roof load width of 7500 mm in a 3000 mm stud height row.

**ADOPT:**

Smart10 LVL - 2/70 x 35

Tile roof 90 kg/m <sup>2</sup>													
Stud spacing (mm)		450						600					
Floor joist spacing (mm)		450			600			450			600		
Upper floor load width (mm)		1800	3600	4800	1800	3600	4800	1800	3600	4800	1800	3600	4800
Size DxB (mm)	Stud height (mm)	Roof load width (RLW) (mm)											
70x35	2400	6500	5500	5500	4500	3500	3500	3500	2500	1500	3500	2500	1500
	2700	2500	1500	1500	1500	NS	NS	NS	NS	NS	NS	NS	NS
70x45	2400	7500	7500	7500	7500	6500	6500	5500	5500	4500	5500	5500	4500
	2700	5500	4500	4500	3500	3000	2500	2500	1500	NS	2500	1500	NS
2/70x35	2400	7500	7500	7500	7500	7500	7500	7500	7500	7500	7500	7500	7500
	2700	7500	7500	7500	7500	7500	7500	7500	6500	6500	7500	6500	6500
	3000	7500	6500	6500	5500	4500	3500	3500	3500	2500	3500	3500	2500
2/70x45	2700	7500	7500	7500	7500	7500	7500	7500	7500	7500	7500	7500	7500
	3000	7500	7500	7500	7500	7500	6500	6500	6500	6500	5500	6500	6500
	3000	7500	7500	7500	7500	7500	6500	6500	6500	6500	5500	6500	5500
90x35	2400	7500	7500	7500	7500	7500	7500	7500	7500	7500	7500	7500	7500
	2700	7500	7500	7500	7500	7500	7500	6500	5500	5500	6500	5500	5500
	3000	6500	5500	5500	4500	3500	3500	2500	1500	1500	2500	1500	1500
90x45	2700	7500	7500	7500	7500	7500	7500	7500	7500	7500	7500	7500	7500
	3000	7500	7500	7500	7500	6500	6500	5500	5500	4500	5500	5500	4500
	3000	7500	7500	7500	7500	7500	7500	7500	7500	7500	7500	7500	7500
2/90x35	3000	7500	7500	7500	7500	7500	7500	7500	7500	7500	7500	7500	
2/90x45	3000	7500	7500	7500	7500	7500	7500	7500	7500	7500	7500	7500	
120x35	3000	7500	7500	7500	7500	7500	7500	7500	7500	7500	7500	7500	
120x45	3000	7500	7500	7500	7500	7500	7500	7500	7500	7500	7500	7500	
2/120x35	3000	7500	7500	7500	7500	7500	7500	7500	7500	7500	7500	7500	
2/120x45	3000	7500	7500	7500	7500	7500	7500	7500	7500	7500	7500	7500	
140x35	3000	7500	7500	7500	7500	7500	7500	7500	7500	7500	7500	7500	
140x45	3000	7500	7500	7500	7500	7500	7500	7500	7500	7500	7500	7500	
2/140x35	3000	7500	7500	7500	7500	7500	7500	7500	7500	7500	7500	7500	
2/140x45	3000	7500	7500	7500	7500	7500	7500	7500	7500	7500	7500	7500	
170x35	3000	7500	7500	7500	7500	7500	7500	7500	7500	7500	7500	7500	

**NOTES :**

1. D = member depth, B = member breadth, NS = not suitable.
2. Total upper floor mass of 40 kg/m<sup>2</sup>, total wall mass of 37 kg/m<sup>2</sup>, floor live load of 1.5 kPa
3. Stud not notched. Maximum tension load in stud not to exceed 8.5 kN.
4. Where studs are nailed laminated the tension load in each stud shall not exceed 8.5 kN.
5. **Not all sizes of SmartLVL in this table are stocked in each state. Please check with your supplier before ordering**

## Studs lower storey of two (2) storey walls Supporting floor loads only

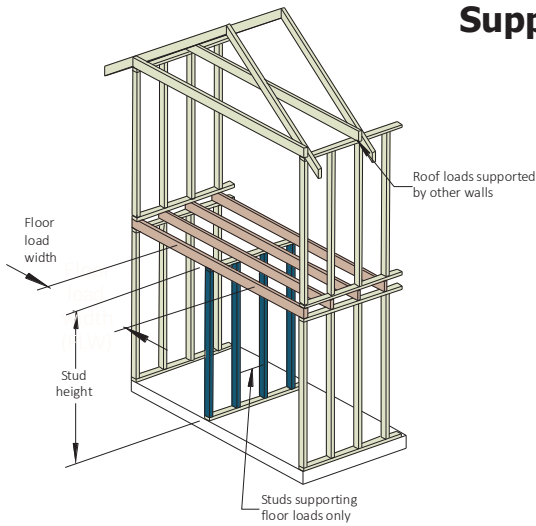

**EXAMPLE:**

Un - notched stud

Stud spacing = 450 mm

Floor joist spacing = 600 mm

Stud height = 2700 mm

Floor load width = 4100 mm

Enter table at 450 mm stud spacing column, 600 mm joist spacing column, read down to a floor load width of 4100 mm in a 2700 mm stud height row.

**ADOPT:**

**Smart10 LVL - 70 x 35**

<b>Un-notched</b>					
Stud spacing (mm)		450		600	
Floor joist spacing (mm)		450	600	450	600
Size DxB (mm)	Stud height (mm)	Maximum recommended floor load width (mm)			
70x35	2400	8000	8000	8000	8000
70x45	2400	8000	8000	8000	8000
	2700	8000	8000	NS	NS
2/70x35	3000	8000	8000	8000	8000
2/70x45	3000	8000	8000	8000	8000
90x35	3000	8000	8000	8000	8000
90x45	3000	8000	8000	8000	8000
2/90x35	3000	8000	8000	8000	8000
2/90x45	3000	8000	8000	8000	8000
120x35	3000	8000	8000	8000	8000
120x45	3000	8000	8000	8000	8000
2/120x35	3000	8000	8000	8000	8000
2/120x45	3000	8000	8000	8000	8000
140x35	3000	8000	8000	8000	8000
140x45	3000	8000	8000	8000	8000
2/140x35	3000	8000	8000	8000	8000
2/140x45	3000	8000	8000	8000	8000
170x35	3000	8000	8000	8000	8000

<b>20 mm notch</b>					
Stud spacing (mm)		450		600	
Floor joist spacing (mm)		450	600	450	600
Size DxB (mm)	Stud height (mm)	Maximum recommended floor load width (mm)			
70x35	2400	6000	6000	6000	6000
2/70x35	2700	6000	6000	6000	6000
	3000	6000	6000	NS	NS
70x45	2400	6000	6000	6000	6000
	2700	6000	4800	NS	NS
2/70x45	3000	6000	6000	6000	6000
90x35	3000	6000	6000	6000	6000
2/90x35	3000	6000	6000	6000	6000
90x45	3000	6000	6000	6000	6000

## Studs lower storey of two (2) storey walls Supporting floor loads only (Cont'd)

20 mm notch					
Stud spacing (mm)		450		600	
Floor joist spacing (mm)		450	600	450	600
Size DxB (mm)	Stud height (mm)	Maximum recommended floor load width (mm)			
2/90x45	3000	6000	6000	6000	6000
120x35	3000	6000	6000	6000	6000
2/120x35	3000	6000	6000	6000	6000
120x45	3000	6000	6000	6000	6000
2/120x45	3000	6000	6000	6000	6000
140x35	3000	6000	6000	6000	6000
2/140x35	3000	6000	6000	6000	6000
140x45	3000	6000	6000	6000	6000
2/140x45	3000	6000	6000	6000	6000
170x35	3000	6000	6000	6000	6000

### NOTES :

1. D = member depth, B = member breadth, NS = not suitable
2. The above table was based on a maximum upper floor mass of 40 kg/m<sup>2</sup>, total wall mass of 15 kg/m<sup>2</sup>, floor live load of 1.5 kPa
3. Multiple studs to be nail laminated as per AS 1684
4. Wall stud notched to a maximum depth of 20 mm.
5. **Not all sizes of SmartLVL in this table are stocked in each state. Please check with your supplier before ordering**



# Studs supporting Concentrated roof loads

## AS 4055 Wind classifications N1-N4 & C1-C3

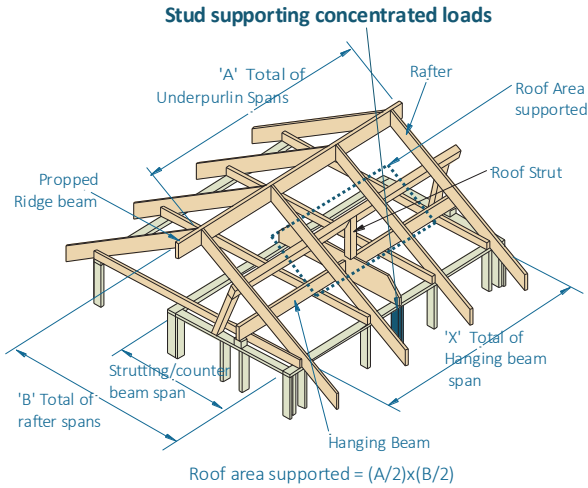

**EXAMPLE:**

Sheet roof

AS 4055 Classification N3

Jamb stud height = 2700 mm

Roof area = 12 m<sup>2</sup>

Enter table N1-N3 wind classification, 2700 stud height, sheet roof column, read down to a roof area of 12

**ADOPT:**

Smart10 LVL - 90 x 35 or 2/70 x 35

AS 4055 Classification N1-N4								
Stud height (mm)	2400	2700	3000	3600	2400	2700	3000	3600
Member size (mm)	Roof area supported (m <sup>2</sup> )							
	Sheet Roof				Tile Roof			
70x35	13	9	7	2	8	6	4	2
70x45	15	11	8	4	10	7	5	2
2/70x35	26	18	13	6	15	11	8	4
2/70x45	31	23	17	8	20	14	10	6
90x35	26	18	14	8	17	12	8	4
90x45	34	26	18	10	20	15	11	6
2/90x35	40	37	29	15	33	23	17	10
2/90x45	40	40	37	20	40	31	23	10
120x35	40	40	34	15	28	24	20	10
120x45	40	40	40	20	40	37	29	15
2/120x35	40	40	40	20	40	40	40	20
2/120x45	40	40	40	40	40	40	40	20
140x35	40	40	40	20	33	30	26	15
140x45	40	40	40	20	40	40	40	20
2/140x35	40	40	40	40	40	40	40	20
2/140x45	40	40	40	40	40	40	40	40
170x35	40	40	40	40	40	40	40	20

AS 4055 Classification C1-C3								
Stud height (mm)	2400	2700	3000	3600	2400	2700	3000	3600
Member size (mm)	Roof area supported (m <sup>2</sup> )							
	Sheet Roof				Tile Roof			
70x35	7	5	4	2	6	4	3	NS
70x45	9	6	4	2	7	5	4	2
2/70x35	14	10	7	4	11	8	6	2
2/70x45	18	13	9	4	15	10	7	4
90x35	15	10	7	4	11	8	6	2
90x45	18	14	10	4	15	11	8	4

## Studs supporting Concentrated roof loads AS 4055 Wind classifications N1-N4 & C1-C3

AS 4055 Classification C1-C3								
Stud height (mm)	2400	2700	3000	3600	2400	2700	3000	3600
Member size (mm)	Roof area supported (m <sup>2</sup> )							
	Sheet Roof				Tile Roof			
2/90x35	30	20	15	8	23	17	13	6
2/90x45	37	29	20	10	31	23	15	8
120x35	27	23	18	10	24	20	15	8
120x45	40	34	26	10	32	25	18	10
2/120x35	40	40	37	20	40	40	31	15
2/120x45	40	40	40	20	40	40	37	20
140x35	31	28	25	15	28	25	21	10
140x45	40	40	37	20	40	40	31	15
2/140x35	40	40	40	20	40	40	40	20
2/140x45	40	40	40	40	40	40	40	20
170x35	35	31	28	20	32	29	26	20

### NOTES:

1. D = member depth, B = member breadth, NS = not suitable
2. The above table was based on a maximum sheet roof mass of 40 kg/m<sup>2</sup>, tile roof mass of 90 kg/m<sup>2</sup>
3. Multiple studs to be laminated as per AS 1684
4. Support crushing check is not considered, minimum of 2 studs under concentrated loads is highly recommended to avoid crushing of the bottom plates
5. Maximum tension load in stud not to exceed 8.5 kN. Where studs are nailed laminated the tension load in each stud shall not exceed 8.5 kN
6. **Not all sizes of SmartLVL in this table are stocked in each state. Please check with your supplier before ordering**

# Floor joists supporting floor loads only

Floor mass - 40 kg/m<sup>2</sup>

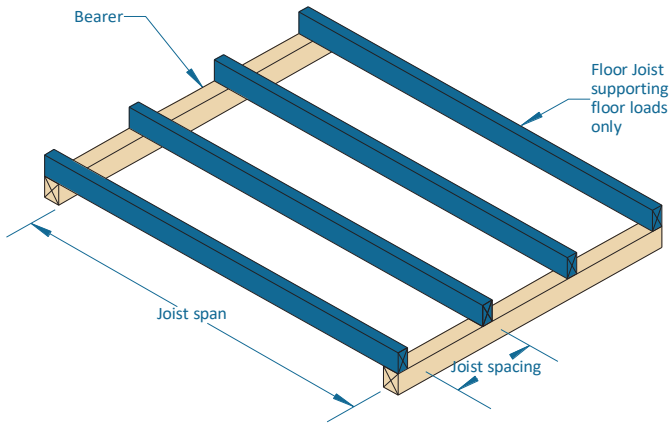

**EXAMPLE:**

Domestic floor loads  
 Continuous span  
 Joist spacing = 450 mm  
 Joist span = 2000 mm

Enter continuous span table at 450 mm in joist spacing column, read down to a span equal to or greater than 2000 mm

**ADOPT:**

**Smart10 LVL - 120x35**

Loadings: permanent - self weight + 40 kg/m<sup>2</sup> + 0.5 kPa of the live load, live load - 1.5 kPa or floor point load of 1.8 kN

Joist spacing (mm)	300	450	600	300	450	600
Member size Dx B (mm)	Maximum recommended span (mm)					
	Single span			Continuous span		
90x35	1400	1300	1300	1800	1600	1500
120x35	2400	2000	1800	3100	2300	2100
140x35	3000	2300	2200	3700	2800	2500
170x35	3800	2900	2700	4500	3500	3100
190x35	4200	3300	3000	4800	4100	3500
240x35	5000	4400	3900	5800	5200	4600
290x35	5700	5200	4800	6700	6000	5600
90x45	1700	1500	1500	2100	1800	1700
120x45	2700	2200	2000	3400	2600	2300
140x45	3500	2600	2400	4100	3100	2800
170x45	4100	3200	2900	4700	3900	3400
190x45	4400	3700	3300	5200	4500	3900
240x45	5300	4800	4300	6100	5600	5100
290x45	6100	5500	5100	7100	6400	6000
300x45	6300	5700	5300	7300	6600	6100

**NOTES:**

- D = member depth, B = member breadth, NS = not suitable
- Spans are suitable for solid timber, particle board and ply flooring. floor sheeting glued and nailed to joists will improve floor rigidity. Where heavy overlay material is to be applied, such as a mortar bed tiled or slate floor, the permanent load allowance should be increased to 1.2 kPa. A reduction of joist spacing may be used to accommodate this extra permanent load. A satisfactory result can be achieved by adopting the maximum spans for 600 mm and 450 mm spacing but installing the joists at 450 and 300 mm spacing respectively
- For beams which are continuous over two unequal spans, the design span and the 'resultant span description' depend upon the percentage span differences between the two spans as shown below

Span Difference %	Effective span	Resultant span Description
10% max	Main span	Continuous
10 - 30%	1.1 x Main span	Continuous
above 30%	Main span	Single

$$\text{span difference} = \frac{(\text{main span} - \text{second span}) \times 100}{(\text{main span} + \text{second span})}$$



- End bearing lengths = 42 mm at end supports and 58 mm at internal supports for continuous members
- Not all sizes of SmartLVL in this table are stocked in each state. Please check with your supplier before ordering.**

# Floor bearers supporting floor loads only

Floor mass - 40 kg/m<sup>2</sup>

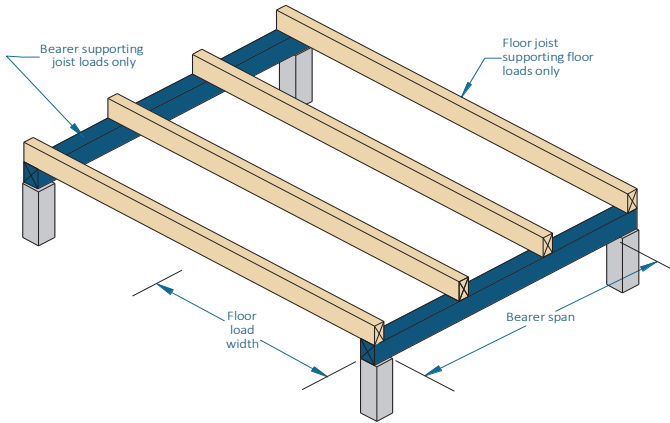

**EXAMPLE:**

Domestic floor loads

Single span

Bearer span = 3000 mm

Floor load width = 4000 mm

Enter single span table at 4200 mm floor load width column and read down to a span equal to or greater than 3000 mm

**ADOPT:**

**Smart10 LVL - 300x45**

Loadings: permanent - self weight + 40 kg/m<sup>2</sup> + 0.5 kPa of the live load, live load - 1.5 kPa or floor point load of 1.8 kN

Floor load width (mm)	1200	1800	2400	3000	3600	4200	4800	5400	6000	6600
Size Dx B (mm)	Maximum recommended bearer span (mm)									
	Single span									
120x45	1900	1700	1500	1400	1300	1200	1200	1100	1100	1000
140x45	2200	1900	1700	1600	1500	1400	1400	1300	1200	1200
170x45	2700	2400	2100	2000	1800	1700	1700	1600	1500	1500
190x45	3000	2600	2400	2200	2100	1900	1800	1800	1700	1600
240x45	3700	3300	3000	2800	2600	2500	2300	2200	2100	2000
290x45	4300	3900	3600	3400	3200	3000	2800	2700	2500	2400
300x45	4400	4000	3700	3500	3300	3100	2900	2800	2600	2500 <sub>5</sub>
2/90x45	1800	1600	1400	1300	1200	1100	1100	1000	1000	NS
2/120x45	2400	2100	1900	1700	1600	1500	1500	1400	1300	1300
2/140x45	2800	2400	2200	2000	1900	1800	1700	1600	1600	1500
2/170x45	3400	3000	2700	2500	2300	2200	2100	2000	1900	1800
2/190x45	3700	3300	3000	2800	2600	2500	2300	2200	2100	2100
2/240x45	4400	4000	3700	3500	3300	3100	3000	2800	2700	2600
2/290x45	5100	4600	4300	4000	3900	3700	3600	3400	3300	3200
2/300x45	5200	4700	4400	4200	4000	3800	3700	3500	3400	3300
<b>Continuous span</b>										
120x45	2400	2100	1800	1600	1500	1300	1200	1200	1100	1000
140x45	2800	2400	2100	1900	1700	1500	1400	1400	1300	1200
170x45	3300	2900	2500	2200	2000	1900	1700	1600	1500	1500 <sub>5</sub>
190x45	3600	3200	2800	2500	2200	2100	1900	1800 <sub>5</sub>	1700 <sub>10</sub>	1600 <sub>15</sub>
240x45	4300	3900	3400	3100	2800 <sub>5</sub>	2600 <sub>15</sub>	2400 <sub>20</sub>	2200 <sub>30</sub>	2100 <sub>35</sub>	2000 <sub>50</sub>
290x45	5000	4500	4100 <sub>5</sub>	3600 <sub>15</sub>	3300 <sub>25</sub>	3100 <sub>35</sub>	2800 <sub>55</sub>	2700 <sub>70</sub>	2500 <sub>75</sub>	2400 <sub>85</sub>
300x45	5100	4600	4200 <sub>5</sub>	3800 <sub>20</sub>	3400 <sub>30</sub>	3200 <sub>45</sub>	2900 <sub>65</sub>	2800 <sub>75</sub>	2600 <sub>80</sub>	2500 <sub>90</sub>
2/90x45	2200	2000	1800	1600	1500	1500	1400	1300	1300	1200
2/120x45	3000	2600	2400	2200	2100	2000	1900	1800	1700	1600
2/140x45	3400	3100	2800	2600	2400	2300	2200	2100	2000	1900
2/170x45	4000	3600	3300	3100	3000	2800	2600	2500	2300	2200
2/190x45	4300	3900	3600	3400	3300	3100	2900	2700	2600	2500
2/240x45	5200	4700	4300	4100	3900	3800	3600	3400	3200 <sub>5</sub>	3100 <sub>10</sub>
2/290x45	6000	5400	5000	4700	4500	4400	4200 <sub>5</sub>	4000 <sub>15</sub>	3800 <sub>25</sub>	3600 <sub>30</sub>
2/300x45	6100	5500	5100	4900	4600	4500	4300 <sub>10</sub>	4200 <sub>20</sub>	4000 <sub>30</sub>	3800 <sub>35</sub>

**NOTES:**

1. D = member depth, B = member breadth, NS = not suitable
2. The above table was based upon a maximum DL of 40 kg/m<sup>2</sup> + 0.5 kPa of LL, Floor live load of 1.5 kPa, floor point load of 1.8 kN
3. End bearing lengths = 42 mm at end supports and 58 mm at internal supports for continuous members. Subscript values indicate the minimum additional bearing length required to be greater at 42 mm end supports and 58 mm internal supports
4. Restraint values for slenderness calculation is 600 mm (floor joist at 600 mm centres Max)
5. **Not all sizes of SmartLVL in this table are stocked in each state. Please check with your supplier before ordering**

# Floor bearers supporting single storey load bearing wall - sheet and tiled roof

Floor mass - 40 kg/m<sup>2</sup>

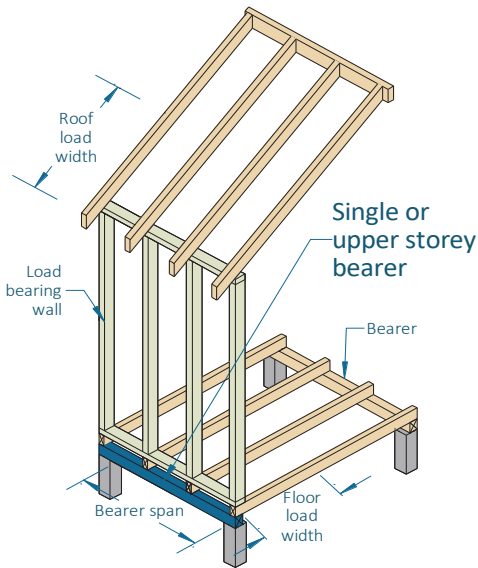

**EXAMPLE:**

- sheet roof - 40 kg/m<sup>2</sup>
- roof load width = 1950 mm
- bearer span = 2500 mm (single span)
- floor load width = 2200 mm

Enter single span table at 2400 mm in floor load width column, 4500 roof load width column, read down to a span equal to or greater than 2500 mm in the 40 kg/m<sup>2</sup> row.

**ADOPT:**

**Smart10 LVL —290x45**

Floor load width (mm)		1200			2400			4800		
Roof load width (mm)		1500	4500	7500	1500	4500	7500	1500	4500	7500
Member size DxB (mm)	Roof mass (kg/m <sup>2</sup> )	Maximum recommended single span floor bearer supporting single storey load bearing wall span (mm)								
140x45	40	1600	1400	1200	1500	1300	1200	1200	1100	1100
	90	1500	1200	1100	1400	1200	1000	1200	1000	NS
170x45	40	2000	1700	1500	1800	1600	1400	1500	1400	1300
	90	1800	1500	1300	1700	1400	1200	1400	1300	1200
190x45	40	2200	1900	1700	2000	1800	1600	1700	1600	1400
	90	2100	1700	1500	1900	1600	1400	1600	1400	1300
240x45	40	2800	2400	2200	2500	2300	2000	2100	2000	1800
	90	2600	2100	1800	2400	2000	1800	2100	1800	1700
290x45	40	3400	3000	2600	3100	2700	2500	2600	2400	2200
	90	3200	2600	2200	2900	2400	2200	2500	2200	2000 <sub>5</sub>
300x45	40	3600	3100	2700	3200	2800	2600	2700	2500	2300
	90	3300	2700	2300	3000	2500	2200	2600	2300	2100 <sub>10</sub>
2/140x45	40	2100	1800	1600	1800	1600	1500	1600	1400	1300
	90	1900	1500	1300	1700	1500	1300	1500	1300	1200
2/170x45	40	2500	2200	1900	2200	2000	1800	1900	1800	1600
	90	2300	1900	1600	2100	1800	1600	1800	1600	1500
2/190x45	40	2800	2400	2200	2500	2200	2000	2100	2000	1800
	90	2600	2100	1800	2400	2000	1800	2000	1800	1600
2/240x45	40	3600	3100	2700	3200	2800	2600	2700	2500	2300
	90	3300	2700	2300	3000	2500	2200	2600	2300	2100
2/290x45	40	4100	3700	3300	3800	3400	3100	3300	3000	2800
	90	3900	3200	2800	3600	3100	2700	3100	2800	2500
2/300x45	40	4200	3800	3400	3900	3600	3200	3400	3100	2900
	90	4000	3400	2900	3700	3200	2800	3200	2900	2600
<b>Maximum recommended single span floor bearer supporting single storey load bearing wall span (mm)</b>										
140x45	40	2200	1900	1600	1800	1700	1500	1300	1300	1200
	90	2100	1600	1300	1700	1500	1200	1300	1200	1100
170x45	40	2700	2400	2000	2200	2000	1800	1600	1500	1400 <sub>5</sub>
	90	2500	1900	1600	2100	1700	1500 <sub>5</sub>	1600	1400 <sub>10</sub>	1300 <sub>20</sub>
190x45	40	3100	2600	2200	2400	2200	2000	1800 <sub>5</sub>	1700 <sub>10</sub>	1600 <sub>20</sub>
	90	2800	2100	1700 <sub>10</sub>	2300	1900	1600 <sub>15</sub>	1700 <sub>10</sub>	1600 <sub>20</sub>	1400 <sub>30</sub>
240x45	40	3800	3200	2700 <sub>10</sub>	3000	2700 <sub>5</sub>	2500 <sub>20</sub>	2200 <sub>30</sub>	2100 <sub>40</sub>	2000 <sub>55</sub>
	90	3600	2600 <sub>15</sub>	2100 <sub>40</sub>	2900 <sub>5</sub>	2400 <sub>20</sub>	2000 <sub>50</sub>	2200 <sub>35</sub>	2000 <sub>60</sub>	1800 <sub>75</sub>
290x45	40	4400	3800 <sub>5</sub>	3200 <sub>30</sub>	3600 <sub>15</sub>	3300 <sub>30</sub>	2900 <sub>45</sub>	2700 <sub>70</sub>	2500 <sub>75</sub>	2400 <sub>90</sub>
	90	4100	3100 <sub>30</sub>	2600 <sub>75</sub>	3400 <sub>20</sub>	2900 <sub>50</sub>	2400 <sub>85</sub>	2600 <sub>70</sub>	2300 <sub>90</sub>	2100 <sub>105</sub>
300x45	40	4500	4000 <sub>10</sub>	3300 <sub>35</sub>	3700 <sub>20</sub>	3400 <sub>30</sub>	3000 <sub>55</sub>	2800 <sub>75</sub>	2600 <sub>80</sub>	2400 <sub>95</sub>
	90	4200	3300 <sub>40</sub>	2600 <sub>80</sub>	3500 <sub>25</sub>	3000 <sub>65</sub>	2500 <sub>90</sub>	2700 <sub>80</sub>	2400 <sub>95</sub>	2200 <sub>110</sub>

## Floor bearers supporting single storey load bearing wall - sheet and tiled roof (cont'd)

Floor load width (mm)		1200			2400			4800		
Roof load width (mm)		1500	4500	7500	1500	4500	7500	1500	4500	7500
Member size DxB (mm)	Roof mass (kg/m <sup>2</sup> )	Maximum recommended single span floor bearer supporting single storey load bearing wall span (mm)								
2/140x45	40	2800	2400	2200	2500	2200	2000	2100	1900	1800
	90	2600	2100	1800	2400	2000	1800	2000	1800	1600
2/170x45	40	3400	3000	2600	3100	2700	2500	2500	2300	2200
	90	3200	2600	2200	2900	2400	2200	2400	2200	2000
2/190x45	40	3800	3300	2900	3400	3100	2800	2700	2600	2400
	90	3600	2900	2500	3200	2700	2400	2600	2400	2200
2/240x45	40	4500	4000	3700	4100	3800	3500	3400	3200 <sub>5</sub>	3000 <sub>10</sub>
	90	4200	3600	3200	3900	3500	3100 <sub>10</sub>	3300	3000 <sub>10</sub>	2700 <sub>20</sub>
2/290x45	40	5200	4600	4200	4700	4400	4100	4000 <sub>20</sub>	3800 <sub>25</sub>	3600 <sub>30</sub>
	90	4900	4200	3800 <sub>20</sub>	4500	4000 <sub>5</sub>	3600 <sub>30</sub>	3900 <sub>20</sub>	3500 <sub>35</sub>	3200 <sub>55</sub>
2/300x45	40	5300	4800	4400	4900	4500	4200	4200 <sub>20</sub>	3900 <sub>30</sub>	3700 <sub>35</sub>
	90	5000	4300	3900 <sub>25</sub>	4700	4100 <sub>5</sub>	3800 <sub>35</sub>	4000 <sub>25</sub>	3700 <sub>40</sub>	3300 <sub>65</sub>

### NOTES:

- D = member depth, B = member breadth, NS = not suitable.
- The above table was based on total ground floor mass of 40 kg/m<sup>2</sup> + 0.5 kPa of LL, wall mass of 37 kg/m<sup>2</sup>, floor live load of 1.5 kPa, floor point load of 1.8 kN
- The above table was based on a wall height of 2700 mm
- End bearing lengths = 70 mm at end supports and 70 mm at internal supports for continuous members. Subscript values indicate the minimum additional bearing length where required to be greater than 70 mm at end supports and 70 mm at internal supports.
- Restraint value for slenderness calculations is 600 mm
- Not all sizes of SmartLVL in this table are stocked in each state. Please check with your supplier before ordering**



# Single span lintels in single/upper storey walls

## AS 4055 classification N1-N4

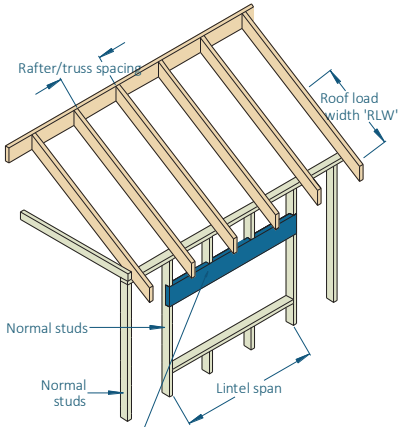

Single/Upper storey lintel

**EXAMPLE:**

wind speed = N3  
 sheet roof - 40 kg/m<sup>2</sup>  
 rafter/truss spacing = 600 mm  
 lintel span = 1300 mm  
 roof load width = 3900 mm

Enter span table at 4500 roof load width column, rafter/truss spacing 600 mm, and read down to a span equal to or greater than 1300 mm in the 40 kg/m<sup>2</sup> row

**ADOPT:**

Smart10 LVL - 120 x 35

Wind classification N1-N4											
Roof load width (mm)		1500		3000		4500		6000		7500	
Rafter/truss spacing (mm)		600	1200	600	1200	600	1200	600	1200	600	1200
Size DxH (mm)	Roof mass (kg/m <sup>2</sup> )	Maximum recommended lintel span (mm)									
90x35	40	1500	1400	1200	NS	1000	NS	NS	NS	NS	NS
	90	1200	1000	NS	NS	NS	NS	NS	NS	NS	NS
120x35	40	2100	2100	1600	1500	1400	1100	1200	NS	1100	NS
	90	1600	1500	1300	1100	1100	NS	NS	NS	NS	NS
120x35	40	2100	2100	1600	1500	1400	1100	1200	NS	1100	NS
	90	1600	1500	1300	1100	1100	NS	NS	NS	NS	NS
140x35	40	2400	2500	1900	1900	1600	1500	1400 <sub>5</sub>	1100	1300 <sub>10</sub>	NS
	90	1900	1900	1500	1300	1300	1100	1100	NS	1000 <sub>5</sub>	NS
170x35	40	3000	3000	2300	2300	2000	2000 <sub>5</sub>	1700	1600 <sub>10</sub>	1600 <sub>10</sub>	1300 <sub>10</sub>
	90	2300	2300	1800	1800	1500	1400 <sub>15</sub>	1400 <sub>10</sub>	1200 <sub>10</sub>	1300 <sub>20</sub>	1000 <sub>20</sub>
2/90x35	40	2000	2000	1500	1400	1300	1100	1200	1000	1000	NS
	90	1500	1400	1200	1000	1000	NS	NS	NS	NS	NS
2/120x35	40	2600	2700	2000	2000	1700	1700	1500	1500	1400	1300
	90	2000	2000	1600	1500	1400	1200	1200	1000	1100	NS
2/120x35	40	2600	2700	2000	2000	1700	1700	1500	1500	1400	1300
	90	2000	2000	1600	1500	1400	1200	1200	1000	1100	NS
2/140x35	40	3000	3000	2400	2400	2100	2000	1800	1800	1600	1600
	90	2400	2400	1900	1900	1600	1500	1400	1300	1300	1200
2/170x35	40	3500	3500	2900	2900	2500	2500	2200	2200	2000	2000
	90	2900	2900	2300	2300	2000	1900	1800	1700	1600	1500 <sub>5</sub>
90x45	40	1700	1600	1300	1100	1100	NS	1000	NS	NS	NS
	90	1300	1100	1000	NS	NS	NS	NS	NS	NS	NS
120x45	40	2300	2300	1700	1700	1500	1400	1400	1000	1200	NS
	90	1700	1700	1400	1200	1200	1000	1000	NS	NS	NS
120x45	40	2300	2300	1700	1700	1500	1400	1400	1000	1200	NS
	90	1700	1700	1400	1200	1200	1000	1000	NS	NS	NS
140x45	40	2700	2700	2100	2000	1800	1700	1600	1400 <sub>5</sub>	1400 <sub>5</sub>	1100
	90	2100	2000	1600	1500	1400	1200	1200	1100 <sub>5</sub>	1100	NS
170x45	40	3200	3100	2500	2600	2200	2100	1900	1900 <sub>5</sub>	1700	1600 <sub>10</sub>
	90	2500	2600	2000	1900	1700	1600	1500 <sub>5</sub>	1400 <sub>5</sub>	1400 <sub>10</sub>	1200 <sub>10</sub>
190x45	40	3400	3400	2800	2800	2400	2400 <sub>5</sub>	2100 <sub>5</sub>	2100 <sub>5</sub>	1900 <sub>5</sub>	1900 <sub>15</sub>
	90	2800	2800	2200	2200	1900	1900	1700	1700 <sub>15</sub>	1600 <sub>15</sub>	1500 <sub>30</sub>
240x45	40	4100	4100	3400	3400	3000	3000 <sub>5</sub>	2700 <sub>10</sub>	2700 <sub>25</sub>	2500 <sub>20</sub>	2500 <sub>30</sub>
	90	3400	3400	2800	2800 <sub>5</sub>	2400 <sub>10</sub>	2400 <sub>15</sub>	2200 <sub>20</sub>	2100 <sub>15</sub>	2000 <sub>10</sub>	2000 <sub>25</sub>
290x45	40	4700	4700	3900	3900	3500 <sub>10</sub>	3500 <sub>10</sub>	3200 <sub>10</sub>	3200 <sub>20</sub>	3000 <sub>25</sub>	3000 <sub>35</sub>
	90	3900	3900	3300	3200	2900 <sub>15</sub>	2900 <sub>20</sub>	2600 <sub>25</sub>	2600 <sub>35</sub>	2400 <sub>35</sub>	2400 <sub>50</sub>
300x45	40	4800	4800	4000	4000	3600 <sub>10</sub>	3600 <sub>10</sub>	3300 <sub>10</sub>	3300 <sub>20</sub>	3100 <sub>25</sub>	3000 <sub>40</sub>
	90	4000	4000	3400	3300	3000 <sub>10</sub>	3000 <sub>20</sub>	2700 <sub>25</sub>	2800 <sub>25</sub>	2500 <sub>25</sub>	2500 <sub>50</sub>

## Single span lintels in single/upper storey walls (cont'd)

### AS 4055 classification N1-N4

Wind classification N1-N4											
Roof load width (mm)		1500		3000		4500		6000		7500	
Rafter/truss spacing (mm)		600	1200	600	1200	600	1200	600	1200	600	1200
Size Dx B (mm)	Roof mass (kg/m <sup>2</sup> )	Maximum recommended lintel span (mm)									
2/90x45	40	2100	2100	1600	1600	1400	1300	1300	1100	1100	1000
	90	1600	1600	1300	1100	1100	NS	1000	NS	NS	NS
2/120x45	40	2800	2800	2200	2200	1900	1900	1700	1600	1500	1500
	90	2200	2200	1700	1700	1500	1400	1400	1200	1200	1000
2/120x45	40	2800	2800	2200	2200	1900	1900	1700	1600	1500	1500
	90	2200	2200	1700	1700	1500	1400	1400	1200	1200	1000
2/140x45	40	3200	3200	2600	2600	2200	2200	2000	2000	1800	1800
	90	2600	2600	2000	2000	1700	1700	1600	1500	1400	1300
2/170x45	40	3700	3700	3100	3100	2700	2700	2400	2400	2200	2200
	90	3100	3100	2500	2500	2100	2100	1900	1900	1800	1700
2/190x45	40	4000	4000	3400	3300	3000	3000	2700	2700	2500	2500
	90	3400	3300	2800	2800	2400	2400	2200	2100	2000	1900
2/240x45	40	4800	4700	4000	4000	3600	3600	3300	3300	3100	3100
	90	4000	4000	3400	3300	3000	3000	2700	2800 <sub>5</sub>	2500	2500 <sub>10</sub>
2/290x45	40	5400	5400	4600	4600	4100	4100	3800	3800	3600 <sub>5</sub>	3500 <sub>5</sub>
	90	4600	4600	3900	3900	3500	3500	3200	3200	3000 <sub>5</sub>	3000 <sub>10</sub>
2/300x45	40	5600	5600	4700	4700	4200	4200	3900	3900	3800 <sub>5</sub>	3800 <sub>5</sub>
	90	4700	4700	4000	4000	3600	3500	3300	3300	3100 <sub>5</sub>	3100 <sub>10</sub>

## Single span lintels in single/upper storey walls

### AS 4055 classification C1-C3

Wind classification C1-C3											
Roof load width (mm)		1500		3000		4500		6000		7500	
Rafter/truss spacing (mm)		600	1200	600	1200	600	1200	600	1200	600	1200
Size Dx B (mm)	Roof Mass (kg/m <sup>2</sup> )	Maximum recommended lintel span (mm)									
90x35	40	1300	NS	NS	NS	NS	NS	NS	NS	NS	NS
	90	1200	NS	NS	NS	NS	NS	NS	NS	NS	NS
120x35	40	1800	1500	1200	NS	NS	NS	NS	NS	NS	NS
	90	1600	1500	1300	NS	NS	NS	NS	NS	NS	NS
120x35	40	1800	1500	1200	NS	NS	NS	NS	NS	NS	NS
	90	1600	1500	1300	NS	NS	NS	NS	NS	NS	NS
140x35	40	2100	2000	1400	1000	1200 <sub>10</sub>	NS	NS	NS	NS	NS
	90	1900	1900	1400 <sub>5</sub>	1000 <sub>5</sub>	1200 <sub>20</sub>	NS	NS	NS	NS	NS
170x35	40	2600	2600	1800	1500 <sub>15</sub>	1400 <sub>20</sub>	NS	1300 <sub>30</sub>	NS	NS	NS
	90	2300	2300	1800 <sub>5</sub>	1500 <sub>20</sub>	1400 <sub>30</sub>	1000 <sub>20</sub>	1300 <sub>40</sub>	NS	NS	NS
2/90x35	40	1900	1900	1400	NS	1100	NS	NS	NS	NS	NS
	90	1500	1400	1200	1000	1000	NS	NS	NS	NS	NS
2/120x35	40	2600	2700	1900	1700	1500	1100	1300	NS	1200 <sub>5</sub>	NS
	90	2000	2000	1600	1500	1400	1100	1200	NS	1100	NS
2/120x35	40	2600	2700	1900	1700	1500	1100	1300	NS	1200 <sub>5</sub>	NS
	90	2000	2000	1600	1500	1400	1100	1200	NS	1100	NS
2/140x35	40	3000	3000	2300	2200	1800	1500	1500	1100	1400 <sub>10</sub>	NS
	90	2400	2400	1900	1900	1600	1500 <sub>5</sub>	1400 <sub>5</sub>	1100 <sub>5</sub>	1300 <sub>10</sub>	NS
2/170x35	40	3500	3500	2800	2700	2300	2200 <sub>5</sub>	1900	1700 <sub>10</sub>	1700 <sub>5</sub>	1400 <sub>10</sub>
	90	2900	2900	2300	2300	2000	1900 <sub>5</sub>	1800 <sub>5</sub>	1700 <sub>15</sub>	1600 <sub>15</sub>	1300 <sub>15</sub>

## Single span lintels in single/upper storey walls

### AS 4055 classification C1-C3

Wind classification C1-C3											
Roof load width (mm)		1500		3000		4500		6000		7500	
Rafter/truss spacing (mm)		600	1200	600	1200	600	1200	600	1200	600	1200
Size DxB (mm)	Roof Mass (kg/m <sup>2</sup> )	Maximum recommended lintel span (mm)									
90x45	40	1500	1000	1000	NS	NS	NS	NS	NS	NS	NS
	90	1300	1100	1000	NS	NS	NS	NS	NS	NS	NS
120x45	40	2000	1900	1400	NS	1100	NS	NS	NS	NS	NS
	90	1700	1700	1400	1000	1100	NS	NS	NS	NS	NS
120x45	40	2000	1900	1400	NS	1100	NS	NS	NS	NS	NS
	90	1700	1700	1400	1000	1100	NS	NS	NS	NS	NS
140x45	40	2400	2300	1600	1300	1300	NS	1200 <sub>15</sub>	NS	NS	NS
	90	2100	2000	1600	1300	1300 <sub>10</sub>	NS	1200 <sub>20</sub>	NS	NS	NS
170x45	40	3000	2900	2100	1900	1600 <sub>5</sub>	1300 <sub>5</sub>	1400 <sub>20</sub>	NS	1300 <sub>25</sub>	NS
	90	2500	2600	2000	1900 <sub>10</sub>	1600 <sub>10</sub>	1300 <sub>10</sub>	1400 <sub>20</sub>	NS	1300 <sub>35</sub>	NS
190x45	40	3300	3200	2400 <sub>5</sub>	2200 <sub>5</sub>	1800 <sub>5</sub>	1600 <sub>20</sub>	1600 <sub>20</sub>	1200 <sub>15</sub>	1400 <sub>25</sub>	NS
	90	2800	2800	2200 <sub>5</sub>	2200 <sub>10</sub>	1800 <sub>10</sub>	1600 <sub>25</sub>	1600 <sub>30</sub>	1200 <sub>25</sub>	1400 <sub>35</sub>	NS
240x45	40	4100	4100	3000 <sub>10</sub>	2900 <sub>15</sub>	2400 <sub>25</sub>	2300 <sub>25</sub>	2100 <sub>20</sub>	1900 <sub>30</sub>	1800 <sub>30</sub>	1500 <sub>30</sub>
	90	3400	3400	2800 <sub>15</sub>	2800 <sub>30</sub>	2400 <sub>35</sub>	2300 <sub>30</sub>	2000 <sub>25</sub>	1900 <sub>40</sub>	1800 <sub>40</sub>	1500 <sub>40</sub>
290x45	40	4700	4700	3600 <sub>20</sub>	3500 <sub>15</sub>	2900 <sub>30</sub>	2800 <sub>50</sub>	2600 <sub>45</sub>	2500 <sub>60</sub>	2300 <sub>60</sub>	2000 <sub>50</sub>
	90	3900	3900	3300 <sub>15</sub>	3200 <sub>20</sub>	2900 <sub>45</sub>	2800 <sub>50</sub>	2500 <sub>60</sub>	2400 <sub>75</sub>	2200 <sub>75</sub>	2200 <sub>65</sub>
300x45	40	4800	4800 <sub>5</sub>	3400 <sub>10</sub>	3200 <sub>15</sub>	2700 <sub>25</sub>	2700 <sub>40</sub>	2400 <sub>45</sub>	2300 <sub>35</sub>	2100 <sub>30</sub>	2100 <sub>50</sub>
	90	4700	4700	4000	4000	3600 <sub>15</sub>	3500 <sub>10</sub>	3300 <sub>15</sub>	3300 <sub>15</sub>	3100 <sub>30</sub>	3100 <sub>40</sub>
2/90x45	40	2100	2100	1600	1200	1300	NS	1100	NS	NS	NS
	90	1600	1600	1300	1100	1100	NS	1000	NS	NS	NS
2/120x45	40	2800	2800	2200	2100	1700	1400	1500	1100	1400	NS
	90	2200	2200	1700	1700	1500	1400	1400	1100	1200	NS
2/120x45	40	2800	2800	2200	2100	1700	1400	1500	1100	1400	NS
	90	2200	2200	1700	1700	1500	1400	1400	1100	1200	NS
2/140x45	40	3200	3200	2600	2600	2100	2000	1800	1500	1600	1200
	90	2600	2600	2000	2000	1700	1700	1600	1500 <sub>5</sub>	1400 <sub>5</sub>	1200 <sub>5</sub>
2/170x45	40	3700	3700	3100	3000	2600	2500 <sub>5</sub>	2300	2100 <sub>5</sub>	2000	1800 <sub>10</sub>
	90	3100	3100	2500	2500	2100	2100	1900	1900 <sub>5</sub>	1800 <sub>5</sub>	1700 <sub>15</sub>
2/190x45	40	4000	4000	3400	3300	2900	2800 <sub>5</sub>	2500 <sub>5</sub>	2400 <sub>15</sub>	2300 <sub>10</sub>	2100 <sub>15</sub>
	90	3400	3300	2800	2800	2400	2400 <sub>10</sub>	2200 <sub>5</sub>	2100 <sub>10</sub>	2000 <sub>5</sub>	1900 <sub>20</sub>
2/240x45	40	4800	4700	4000	4000	3600 <sub>10</sub>	3500 <sub>5</sub>	3200 <sub>10</sub>	3100 <sub>15</sub>	2800 <sub>20</sub>	2800 <sub>35</sub>
	90	4000	4000	3400	3300	3000	3000 <sub>10</sub>	2700 <sub>20</sub>	2800 <sub>30</sub>	2500 <sub>25</sub>	2500 <sub>35</sub>
2/290x45	40	5400	5400	4600	4600	4100 <sub>10</sub>	4100 <sub>20</sub>	3800 <sub>25</sub>	3700 <sub>20</sub>	3500 <sub>35</sub>	3300 <sub>30</sub>
	90	4600	4600	3900	3900	3500 <sub>15</sub>	3500 <sub>10</sub>	3200 <sub>15</sub>	3200 <sub>25</sub>	3000 <sub>30</sub>	3000 <sub>40</sub>
300x45	40										
	90										

#### NOTES:

1. D = member depth, B = member breadth, NS = not suitable.
2. Minimum bearing length = 35 mm at end supports. Subscript values indicate the minimum additional bearing length where required to be greater than 35 mm.
3. Restraint value for slenderness calculations is 600 mm.
4. **Not all sizes of SmartLVL in this table are stocked in each state. Please check with your supplier before ordering**

# Single span lintels in lower storey walls

## AS 4055 classification up to C3

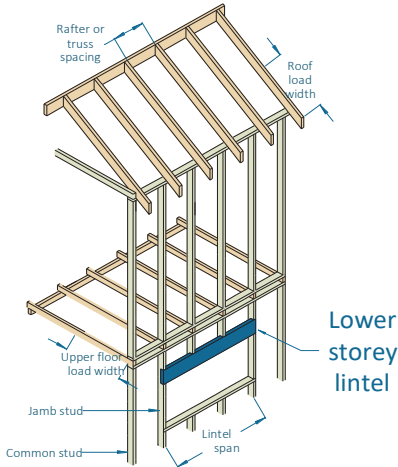

### EXAMPLE:

wind speed = N3

sheet roof - 40 kg/m<sup>2</sup>

rafter/truss spacing = 600 mm

lintel span = 1100 mm

roof load width = 3900 mm

floor load width = 1200 mm

Enter span table at 4500 roof load width column, floor load width 1200 mm, and read down to a span equal to or greater than 1100 mm in the 40 kg/m<sup>2</sup> row

### ADOPT:

Smart10 LVL -2/90 x 45 or 120 x 35

Roof load width (mm)		1500			3000			4500			6000		
Upper floor load width (mm)		1200	2400	3600	1200	2400	3600	1200	2400	3600	1200	2400	3600
Size DxB (mm)	Roof mass (kg/m <sup>2</sup> )	Maximum recommended lintel span (mm)											
120x35	40	1300	1100	1100	1200	1100	1000	1100	1100	1000	1100	1000	NS
	90	1200	1100	1000	1100	1000	NS	1000	NS	NS	NS	NS	NS
140x35	40	1500	1300	1200	1400	1300	1200	1300	1200	1200	1300	1200	1100
	90	1400	1300	1200	1300	1200	1100	1200	1100	1000 <sub>5</sub>	1100	1000 <sub>5</sub>	1000 <sub>5</sub>
170x35	40	1800	1600	1500 <sub>5</sub>	1700	1600	1500 <sub>5</sub>	1600	1500	1400 <sub>5</sub>	1600	1500	1400 <sub>5</sub>
	90	1700	1600	1400 <sub>5</sub>	1500	1400	1400 <sub>5</sub>	1400	1400 <sub>5</sub>	1300 <sub>10</sub>	1300 <sub>10</sub>	1300 <sub>10</sub>	1200 <sub>15</sub>
190x35	40	2100	1800	1700 <sub>5</sub>	1900	1800	1600 <sub>10</sub>	1800	1700	1600 <sub>10</sub>	1800	1600 <sub>5</sub>	1500 <sub>10</sub>
	90	1900	1800	1600 <sub>10</sub>	1700	1600 <sub>5</sub>	1500 <sub>10</sub>	1600 <sub>5</sub>	1500 <sub>10</sub>	1400 <sub>15</sub>	1500 <sub>10</sub>	1400 <sub>15</sub>	1400 <sub>20</sub>
240x35	40	2600	2300 <sub>10</sub>	2200 <sub>20</sub>	2500	2200 <sub>10</sub>	2100 <sub>20</sub>	2300 <sub>5</sub>	2200 <sub>10</sub>	2000 <sub>20</sub>	2200 <sub>10</sub>	2100 <sub>15</sub>	2000 <sub>20</sub>
	90	2400 <sub>5</sub>	2200 <sub>10</sub>	2100 <sub>20</sub>	2200 <sub>10</sub>	2100 <sub>15</sub>	1900 <sub>25</sub>	2000 <sub>20</sub>	1900 <sub>25</sub>	1800 <sub>30</sub>	1900 <sub>25</sub>	1800 <sub>30</sub>	1700 <sub>35</sub>
290x35	40	3100 <sub>5</sub>	2800 <sub>15</sub>	2600 <sub>30</sub>	3000 <sub>10</sub>	2700 <sub>15</sub>	2500 <sub>30</sub>	2800 <sub>15</sub>	2600 <sub>20</sub>	2400 <sub>30</sub>	2700 <sub>15</sub>	2500 <sub>25</sub>	2400 <sub>35</sub>
	90	2900 <sub>10</sub>	2700 <sub>20</sub>	2500 <sub>30</sub>	2700 <sub>20</sub>	2500 <sub>25</sub>	2300 <sub>35</sub>	2500 <sub>25</sub>	2300 <sub>35</sub>	2200 <sub>40</sub>	2300 <sub>35</sub>	2200 <sub>40</sub>	2100 <sub>50</sub>
2/90x35	40	1200	1100	1000	1100	1000	NS	1100	1000	NS	1000	1000	NS
	90	1100	1000	NS	1000	NS	NS	NS	NS	NS	NS	NS	NS
2/120x35	40	1600	1500	1300	1500	1400	1300	1500	1300	1300	1400	1300	1200
	90	1500	1400	1300	1400	1300	1200	1300	1200	1100	1200	1100	1100
2/140x35	40	1900	1700	1600	1800	1600	1500	1700	1600	1500	1600	1500	1400
	90	1800	1600	1500	1600	1500	1400	1500	1400	1300	1400	1300	1300
2/170x35	40	2300	2100	1900	2200	2000	1800	2100	1900	1800	2000	1900	1700
	90	2200	2000	1800	2000	1800	1700	1800	1700	1600	1700	1600	1600
2/190x35	40	2600	2300	2100	2400	2200	2100	2300	2200	2000	2200	2100	2000
	90	2400	2200	2100	2200	2000	1900	2000	1900	1800	1900	1800	1700
2/240x35	40	3200	3000	2700	3100	2800	2600	3000	2700	2500	2800	2600	2500
	90	3000	2800	2600	2800	2600	2400 <sub>5</sub>	2600	2400 <sub>5</sub>	2300 <sub>5</sub>	2400 <sub>5</sub>	2300 <sub>5</sub>	2200 <sub>10</sub>
2/290x35	40	3700	3400	3200 <sub>5</sub>	3500	3300	3100 <sub>5</sub>	3400	3200	3100 <sub>10</sub>	3300	3100 <sub>5</sub>	3000 <sub>10</sub>
	90	3500	3300	3100 <sub>5</sub>	3300	3100 <sub>5</sub>	3000 <sub>10</sub>	3100 <sub>5</sub>	3000 <sub>10</sub>	2800 <sub>15</sub>	2900 <sub>10</sub>	2800 <sub>15</sub>	2700 <sub>20</sub>
120x45	40	1400	1300	1100	1300	1200	1100	1300	1200	1100	1200	1100	1000
	90	1300	1200	1100	1200	1100	1000	1100	1000	1000	1000	1000	NS
140x45	40	1600	1500	1300	1500	1400	1300	1500	1400	1300	1400	1300	1200
	90	1500	1400	1300	1400	1300	1200	1300	1200	1100	1200	1100	1100
170x45	40	2000	1800	1600	1900	1700	1600	1800	1700	1500	1700	1600	1500
	90	1900	1700	1600	1700	1600	1500	1600	1500	1400 <sub>5</sub>	1500	1400 <sub>5</sub>	1300 <sub>5</sub>
190x45	40	2200	2000	1800	2100	1900	1800	2000	1900	1700 <sub>5</sub>	1900	1800	1700 <sub>5</sub>
	90	2100	1900	1800	1900	1800	1700 <sub>5</sub>	1700	1700 <sub>5</sub>	1600 <sub>10</sub>	1600 <sub>5</sub>	1600 <sub>10</sub>	1500 <sub>10</sub>
240x45	40	2800	2500	2300 <sub>10</sub>	2700	2400 <sub>5</sub>	2300 <sub>10</sub>	2500	2400 <sub>5</sub>	2200 <sub>10</sub>	2400 <sub>5</sub>	2300 <sub>5</sub>	2100 <sub>15</sub>
	90	2600	2400 <sub>5</sub>	2200 <sub>10</sub>	2400 <sub>5</sub>	2200 <sub>10</sub>	2100 <sub>15</sub>	2200 <sub>10</sub>	2100 <sub>15</sub>	2000 <sub>20</sub>	2100 <sub>15</sub>	2000 <sub>20</sub>	1900 <sub>25</sub>

## Single span lintels in lower storey walls AS 4055 classification up to C3

Roof load width (mm)		1500			3000			4500			6000		
Upper floor load width (mm)		1200	2400	3600	1200	2400	3600	1200	2400	3600	1200	2400	3600
Size DxB (mm)	Roof mass (kg/m <sup>2</sup> )	Maximum recommended lintel span (mm)											
290x45	40	3300	3100 <sub>10</sub>	2800 <sub>20</sub>	3200	3000 <sub>10</sub>	2700 <sub>20</sub>	3100 <sub>5</sub>	2800 <sub>15</sub>	2700 <sub>20</sub>	3000 <sub>10</sub>	2800 <sub>15</sub>	2600 <sub>25</sub>
	90	3100 <sub>5</sub>	2900 <sub>10</sub>	2700 <sub>20</sub>	2900 <sub>10</sub>	2700 <sub>15</sub>	2600 <sub>25</sub>	2700 <sub>20</sub>	2500 <sub>25</sub>	2400 <sub>30</sub>	2500 <sub>25</sub>	2400 <sub>30</sub>	2300 <sub>35</sub>
300x45	40	3400	3100 <sub>10</sub>	2900 <sub>20</sub>	3200 <sub>5</sub>	3000 <sub>10</sub>	2800 <sub>25</sub>	3100 <sub>5</sub>	2900 <sub>15</sub>	2800 <sub>25</sub>	3000 <sub>10</sub>	2900 <sub>20</sub>	2700 <sub>25</sub>
	90	3200 <sub>5</sub>	3000 <sub>10</sub>	2800 <sub>20</sub>	3000 <sub>15</sub>	2800 <sub>20</sub>	2600 <sub>25</sub>	2800 <sub>20</sub>	2600 <sub>25</sub>	2500 <sub>30</sub>	2600 <sub>25</sub>	2500 <sub>30</sub>	2400 <sub>40</sub>
2/90x45	40	1300	1200	1100	1200	1100	1000	1200	1100	1000	1100	1000	1000
	90	1200	1100	1000	1100	1000	1000	1000	1000	NS	NS	NS	NS
2/120x45	40	1800	1600	1500	1700	1500	1400	1600	1500	1400	1500	1400	1300
	90	1600	1500	1400	1500	1400	1300	1400	1300	1200	1300	1200	1200
2/140x45	40	2100	1900	1700	2000	1800	1700	1900	1700	1600	1800	1700	1600
	90	1900	1800	1600	1700	1600	1500	1600	1500	1500	1500	1400	1400
2/170x45	40	2500	2300	2100	2400	2200	2000	2300	2100	2000	2200	2000	1900
	90	2300	2100	2000	2100	2000	1900	2000	1900	1800	1900	1800	1700
2/190x45	40	2800	2500	2300	2700	2400	2300	2500	2300	2200	2400	2300	2100
	90	2600	2400	2200	2400	2200	2100	2200	2100	2000	2100	2000	1900
2/240x45	40	3400	3100	3000	3300	3000	2900	3100	3000	2800	3000	2900	2700
	90	3200	3000	2800	3000	2800	2700	2800	2700	2500	2600	2500	2400 <sub>5</sub>
2/290x45	40	3900	3600	3400	3800	3500	3300	3600	3400	3200	3500	3300	3200
	90	3700	3500	3300	3500	3300	3200 <sub>5</sub>	3300	3100 <sub>5</sub>	3000 <sub>5</sub>	3100 <sub>5</sub>	3000 <sub>10</sub>	2900 <sub>10</sub>
2/300x45	40	4000	3700	3500	3800	3600	3400	3700	3500	3300	3600	3400	3300
	90	3800	3600	3400	3600	3400	3200 <sub>5</sub>	3400	3200 <sub>5</sub>	3100 <sub>10</sub>	3200 <sub>5</sub>	3100 <sub>10</sub>	3000 <sub>10</sub>

### NOTES:

1. D = member depth, B = member breadth, NS = not suitable.
2. Minimum bearing length = 35 mm at end supports. Subscript values indicate the minimum additional bearing length where required to be greater than 35 mm.
3. Restraint value for slenderness calculations is 600 mm.
4. **Not all sizes of SmartLVL in this table are stocked in each state. Please check with your supplier before ordering.**

# Single/continuous span roof rafter - with ceiling attached

## AS 4055 classification N1-N3

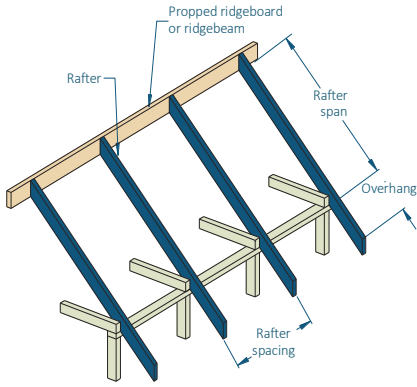

Maximum Birdsmouth = 30% of rafter depth

### EXAMPLE:

wind speed = N3

sheet roof - 40 kg/m<sup>2</sup>

rafter/truss spacing = 600 mm

rafter span = 3000 mm (single span)

Enter span table at rafter spacing of 600 mm, and read down to a span equal to or greater than 3000 mm in the 40 kg/m<sup>2</sup> row

### ADOPT:

Smart10 LVL - 140 x 35

Wind classification N1– N3									
Rafter Spacing (mm)		450	600	900	1200	450	600	900	1200
Size DxB (mm)	Roof & ceiling mass (kg/m <sup>2</sup> )	Maximum recommended single span				Maximum recommended continuous span			
90x35	30	1800	1800	1800	1800	3100	3000	2800	2600
	40	1800	1800	1800	1700	3100	3000	2600	2400
	75	1800	1800	1500	1400	2700	2400	2100	1900
	90	1800	1700	1500	1300	2500	2300	2000	1800
120x35	30	2800	2800	2700	2500	4700	4300	3800	3500
	40	2800	2800	2500	2300	4300	3900	3500	3200
	75	2600	2400	2100	1900	3500	3200	2800	2600
	90	2400	2200	1900	1800	3300	3000	2700	2400
140x35	30	3500	3500	3200	3000	5400	5000	4400	4000
	40	3500	3400	3000	2700	5000	4600	4000	3700
	75	3000	2800	2400	2200	4100	3800	3300	3000
	90	2800	2600	2300	2100	3900	3500	3100	2800
170x35	30	4600	4400	3900	3600	6300	6000	5300	4900
	40	4400	4100	3600	3300	6000	5500	4900	4500
	75	3700	3300	2900	2700	5000	4600	4000	3600
	90	3500	3200	2800	2500	4700	4300	3800	3400
190x35	30	5300	4900	4400	4000	6900	6500	5900	5400
	40	4900	4500	4000	3700	6500	6100	5400	5000
	75	4100	3700	3300	3000	5500	5100	4500	4100
	90	3900	3500	3100	2800	5200	4800	4200	3800
240x35	30	6400	6100	5500	5000	8000	7600	7000	6600
	40	6100	5600	5000	4600	7600	7200	6600	6200
	75	5100	4700	4100	3800	6700	6300	5600	5100
	90	4800	4400	3900	3600	6400	6000	5300	4900
290x35	30	7300	6900	6400	6000	9100	8700	8000	7500
	40	6900	6500	6000	5500	8700	8200	7500	7100
	75	6100	5600	5000	4600	7600	7200	6600	6100
	90	5800	5300	4700	4300	7400	6900	6300	5800
90x45	30	2100	2100	2000	2000	3500	3400	3100	2800
	40	2100	2100	2000	1900	3500	3200	2800	2600
	75	2100	1900	1700	1500	2900	2600	2300	2100
	90	2000	1800	1600	1400	2700	2500	2200	2000
120x45	30	3200	3100	3000	2700	5000	4600	4100	3700
	40	3200	3100	2700	2500	4600	4200	3700	3400
	75	2800	2600	2200	2000	3800	3500	3100	2800
	90	2600	2400	2100	1900	3600	3300	2900	2600



## Single/continuous span roof rafter - with ceiling attached (Cont'd) AS 4055 classification N1-N3

Wind classification N1– N3									
Rafter Spacing (mm)		450	600	900	1200	450	600	900	1200
Size DxB (mm)	Roof & ceiling mass (kg/m <sup>2</sup> )	Maximum recommended single span				Maximum recommended continuous span			
140x45	30	4000	3900	3500	3200	5800	5300	4800	4400
	40	3900	3600	3200	2900	5300	4900	4400	4000
	75	3300	3000	2600	2400	4400	4100	3600	3300
	90	3100	2800	2500	2200	4200	3800	3400	3100
170x45	30	5100	4700	4200	3900	6700	6300	5700	5300
	40	4700	4400	3900	3500	6300	5900	5300	4800
	75	3900	3600	3200	2900	5400	4900	4300	4000
	90	3700	3400	3000	2700	5100	4700	4100	3700
190x45	30	5600	5200	4700	4300	7200	6800	6300	5900
	40	5200	4800	4300	4000	6800	6400	5900	5400
	75	4400	4000	3600	3200	6000	5500	4800	4400
	90	4200	3800	3400	3100	5700	5200	4600	4200
240x45	30	6700	6400	5900	5400	8400	8000	7400	7000
	40	6400	6000	5400	5000	8000	7600	7000	6500
	75	5500	5100	4500	4100	7100	6600	6100	5600
	90	5200	4800	4200	3900	6800	6400	5800	5300
290x45	30	7600	7300	6700	6300	9500	9100	8400	8000
	40	7200	6900	6300	6000	9100	8600	8000	7500
	75	6400	6000	5400	4900	8100	7600	6900	6500
	90	6200	5800	5100	4700	7800	7300	6700	6200
300x45	30								
	40								
	75								
	90								

### NOTES:

1. D = member depth, B = member breadth, NS = not suitable.
2. The above table was based on a batten spacing of 900 mm
3. Maximum birdsmouth depth = 30 % of rafter depth
4. End bearing lengths = 35 mm at end supports and 35 mm at internal supports for continuous members. Subscript values Indicate the minimum additional bearing length where required to be greater than 35 mm at end supports and 35 mm at Internal supports
5. Construction loads shall not be applied to overhangs until a 190x19 (minimum) timber fascia or other fascia of equivalent stiffness is rigidly and permanently attached to the end of rafter overhangs
6. Rafter spacing up to 1200 mm
7. **Not all sizes of SmartLVL in this table are stocked in each state.**

# Single/continuous span roof rafter - with ceiling attached

## AS 4055 classification C1-C3

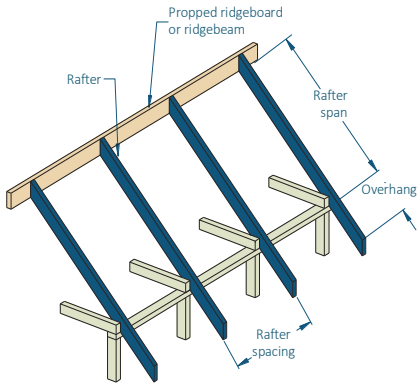

Maximum Birdsmouth = 30% of rafter depth

### EXAMPLE:

wind speed = N3

sheet roof - 40 kg/m<sup>2</sup>

rafter/truss spacing = 600 mm

rafter span = 3000 mm (single span)

Enter span table at rafter spacing of 600 mm, and read down to a span equal to or greater than 3000 mm in the 40 kg/m<sup>2</sup> row

### ADOPT:

Smart10 LVL - 140 x 35

Wind classification C1- C3									
Rafter spacing (mm)		450	600	900	1200	450	600	900	1200
Size DxB (mm)	Roof & ceiling mass (kg/m <sup>2</sup> )	Maximum recommended single span				Maximum recommended continuous span			
90x35	30	1800	1800	1800	1500	2800	2300	1800	1500
	40	1800	1800	1800	1500	2800	2400	1800	1500
	75	1800	1800	1500	1400	2700	2400	1900	1600
	90	1800	1700	1500	1300	2500	2300	1800	1600
120x35	30	2800	2800	2500	2100	3700	3200	2500	2100
	40	2800	2800	2500	2100	3800	3200	2500	2100
	75	2600	2400	2100	1900	3500	3200	2600	2200
	90	2400	2200	1900	1800	3300	3000	2500	2100
140x35	30	3500	3500	2900	2400	4400	3700	2900	2400
	40	3500	3400	3000	2400	4400	3800	3000	2400
	75	3000	2800	2400	2200	4100	3800	3100	2600
	90	2800	2600	2300	2100	3900	3500	3000	2500
170x35	30	4600	4400	3600	3000	5300	4600	3600	3000
	40	4400	4100	3600	3100	5400	4600	3700	3100
	75	3700	3300	2900	2700	5000	4600	3800	3200 <sub>5</sub>
	90	3500	3200	2800	2500	4700	4300	3700	3100 <sub>5</sub>
190x35	30	5200	4800	4100	3400	6000	5100	4100	3400
	40	4900	4500	4000	3500	6000	5200	4100	3500 <sub>5</sub>
	75	4100	3700	3300	3000	5500	5100	4300 <sub>5</sub>	3600 <sub>15</sub>
	90	3900	3500	3100	2800	5200	4800	4200 <sub>10</sub>	3500 <sub>15</sub>
240x35	30	6200	5800	5200	4400	7600	6500	5200 <sub>10</sub>	4400 <sub>15</sub>
	40	6100	5600	5000	4500	7600	6600	5300 <sub>15</sub>	4500 <sub>20</sub>
	75	5100	4700	4100	3800	6700	6300 <sub>5</sub>	5400 <sub>20</sub>	4600 <sub>30</sub>
	90	4800	4400	3900	3600	6400	6000 <sub>5</sub>	5300 <sub>25</sub>	4500 <sub>30</sub>
290x35	30	7200	6700	6000	5400	9000	7900 <sub>10</sub>	6300 <sub>20</sub>	5400 <sub>30</sub>
	40	6900	6500	6000	5400	8700	8000 <sub>15</sub>	6400 <sub>25</sub>	5400 <sub>35</sub>
	75	6100	5600	5000	4600	7600	7200 <sub>15</sub>	6600 <sub>35</sub>	5600 <sub>50</sub>
	90	5800	5300	4700	4300	7400	6900 <sub>15</sub>	6300 <sub>35</sub>	5500 <sub>50</sub>
90x45	30	2100	2100	2000	1700	3200	2700	2100	1700
	40	2100	2100	2000	1800	3200	2700	2100	1800
	75	2100	1900	1700	1500	2900	2600	2200	1800
	90	2000	1800	1600	1400	2700	2500	2100	1800
120x45	30	3200	3100	2800	2300	4200	3600	2800	2300
	40	3200	3100	2700	2400	4300	3700	2900	2400
	75	2800	2600	2200	2000	3800	3500	3000	2500
	90	2600	2400	2100	1900	3600	3300	2900	2400

## Single/continuous span roof rafter - with ceiling attached (Cont'd) AS 4055 classification C1-C3

Wind classification C1- C3									
Rafter spacing (mm)		450	600	900	1200	450	600	900	1200
Size Dx <sub>B</sub> (mm)	Roof & ceiling mass (kg/m <sup>2</sup> )	Maximum recommended single span				Maximum recommended continuous span			
140x45	30	3900	3900	3400	2800	5000	4300	3400	2800
	40	3900	3600	3200	2800	5000	4300	3400	2800
	75	3300	3000	2600	2400	4400	4100	3500	2900
	90	3100	2800	2500	2200	4200	3800	3400	2900
170x45	30	5100	4700	4100	3500	6100	5200	4100	3500
	40	4700	4400	3900	3500	6100	5300	4200	3500
	75	3900	3600	3200	2900	5400	4900	4300	3600
	90	3700	3400	3000	2700	5100	4700	4100	3600
190x45	30	5500	5200	4700	3900	6800	5800	4700	3900
	40	5200	4800	4300	4000	6800	5900	4700	4000
	75	4400	4000	3600	3200	6000	5500	4800	4100 <sub>5</sub>
	90	4200	3800	3400	3100	5700	5200	4600	4000 <sub>5</sub>
240x45	30	6600	6200	5600	5000	8300	7400	5900	5000 <sub>10</sub>
	40	6400	6000	5400	5000	8000	7500	6000 <sub>5</sub>	5100 <sub>10</sub>
	75	5500	5100	4500	4100	7100	6600	6100 <sub>15</sub>	5300 <sub>20</sub>
	90	5200	4800	4200	3900	6800	6400	5800 <sub>10</sub>	5100 <sub>20</sub>
290x45	30	7600	7100	6400	6000	9500	8900 <sub>5</sub>	7200 <sub>15</sub>	6200 <sub>25</sub>
	40	7200	6900	6300	6000	9100	8600 <sub>5</sub>	7300 <sub>15</sub>	6200 <sub>25</sub>
	75	6400	6000	5400	4900	8100	7600	6900 <sub>20</sub>	6400 <sub>35</sub>
	90	6200	5800	5100	4700	7800	7300	6700 <sub>20</sub>	6200 <sub>40</sub>

### NOTES:

1. D = member depth, B = member breadth, NS = not suitable.
2. The above table was based on a batten spacing of 900 mm
3. Maximum birdsmouth depth = 30 % of rafter depth
4. End bearing lengths = 35 mm at end supports and 35 mm at internal supports for continuous members. Subscript values Indicate the minimum additional bearing length where required to be greater than 35 mm at end supports and 35 mm at Internal supports
5. Construction loads shall not be applied to overhangs until a 190x19 (minimum) timber fascia or other fascia of equivalent stiffness is rigidly and permanently attached to the end of rafter overhangs
6. Rafter spacing up to 1200 mm
7. **Not all sizes of SmartLVL in this table are stocked in each state.**

# Single/continuous span roof rafter - without ceiling attached

## AS 4055 classification N1-N3

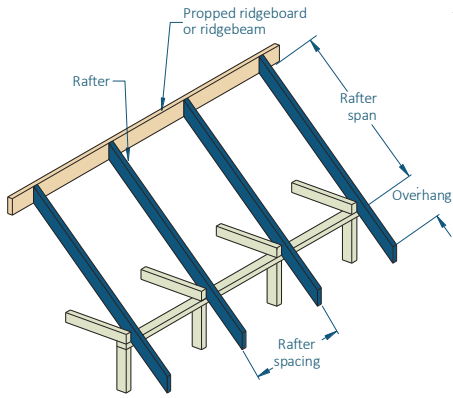

Maximum Birdsmouth = 30% of rafter depth

### EXAMPLE:

wind speed = N3

sheet roof - 40 kg/m<sup>2</sup>

rafter/truss spacing = 600 mm

rafter span = 2400 mm (single span)

Enter span table at rafter spacing of 600 mm, and read down to a span equal to or greater than 2400 mm in the 40 kg/m<sup>2</sup> row

### ADOPT:

Smart10 LVL - 120 x 35

Wind classification N1-N3									
Rafter spacing (mm)		450	600	900	1200	450	600	900	1200
Size Dx B (mm)	Roof & ceiling mass (kg/m <sup>2</sup> )	Maximum recommended single span				Maximum recommended continuous span			
90x35	10	2600	2600	2400	2300	3100	3000	2900	2700
	20	2600	2600	2400	2200	3100	3000	2900	2700
	40	2400	2200	1900	1700	3100	3000	2600	2400
	60	2100	1900	1700	1500	2800	2600	2300	2100
120x35	10	4000	3800	3400	3200	4800	4700	4300	3900
	20	3800	3500	3100	2900	4800	4700	4300	3900
	40	3100	2900	2500	2300	4300	3900	3500	3200
	60	2800	2500	2200	2000	3800	3500	3000	2800
140x35	10	4600	4200	3800	3600	5700	5300	4800	4500
	20	4400	4100	3700	3400	5700	5300	4800	4500
	40	3700	3400	3000	2700	5000	4600	4000	3700
	60	3200	3000	2600	2400	4400	4000	3500	3200
170x35	10	5300	4900	4400	4100	6600	6200	5600	5200
	20	5300	4900	4400	4100	6600	6200	5600	5200
	40	4400	4100	3600	3300	6000	5500	4900	4500
	60	3900	3600	3200	2900	5300	4900	4300	3900
190x35	10	5700	5300	4800	4500	7200	6700	6100	5600
	20	5700	5300	4800	4500	7200	6700	6100	5600
	40	4900	4500	4000	3700	6500	6100	5400	5000
	60	4400	4000	3500	3200	5900	5400	4800	4400
240x35	10	6800	6400	5700	5300	8600	8000	7200	6700
	20	6800	6400	5700	5300	8600	8000	7200	6700
	40	6100	5600	5000	4600	7600	7200	6600	6200
	60	5500	5000	4400	4100	7000	6600	6000	5500
290x35	10	7900	7300	6600	6200	9900	9200	8300	7700
	20	7800	7300	6600	6200	9800	9200	8300	7700
	40	6900	6500	6000	5500	8700	8200	7500	7100
	60	6400	6000	5300	4900	8000	7500	6900	6500
90x45	10	3000	2900	2800	2600	3500	3400	3300	3100
	20	3000	2900	2600	2300	3500	3400	3300	3100
	40	2600	2300	2100	1900	3500	3200	2800	2600
	60	2300	2100	1800	1600	3100	2800	2500	2200
120x45	10	4300	4000	3600	3400	5300	5100	4600	4200
	20	4100	3800	3400	3100	5300	5100	4600	4200
	40	3400	3100	2700	2500	4600	4200	3700	3400
	60	3000	2700	2400	2200	4100	3700	3300	3000

## Single/continuous span roof rafter - without ceiling attached AS 4055 classification N1-N3

Wind classification N1-N3									
Rafter spacing (mm)		450	600	900	1200	450	600	900	1200
Size DxB (mm)	Roof & ceiling mass (kg/m <sup>2</sup> )	Maximum recommended single span				Maximum recommended continuous span			
140x45	10	4900	4500	4100	3800	6100	5700	5100	4800
	20	4700	4400	3900	3600	6100	5700	5100	4800
	40	3900	3600	3200	2900	5300	4900	4400	4000
	60	3500	3200	2800	2600	4800	4400	3800	3500
170x45	10	5600	5200	4700	4400	7100	6600	5900	5500
	20	5600	5200	4700	4400	7100	6600	5900	5500
	40	4700	4400	3900	3500	6300	5900	5300	4800
	60	4200	3900	3400	3100	5700	5300	4700	4300
190x45	10	6100	5700	5100	4800	7700	7100	6400	6000
	20	6100	5700	5100	4800	7700	7100	6400	6000
	40	5200	4800	4300	4000	6800	6400	5900	5400
	60	4700	4300	3800	3500	6300	5900	5200	4700
240x45	10	7300	6800	6100	5700	9100	8500	7700	7200
	20	7200	6800	6100	5700	9000	8500	7700	7200
	40	6300	6000	5400	5000	8000	7600	7000	6500
	60	5900	5400	4800	4400	7400	7000	6400	6000
290x45	10	8400	7800	7000	6600	10500	9800	8900	8200
	20	8100	7800	7000	6600	10100	9800	8900	8200
	40	7200	6900	6300	6000	9100	8600	8000	7500
	60	6700	6300	5800	5300	8400	8000	7300	6800

### NOTES:

1. D = member depth, B = member breadth, NS = not suitable.
2. The above table was based on a batten spacing of 900 mm
3. Maximum birdsmouth depth = 30 % of rafter depth
4. End bearing lengths = 35 mm at end supports and 35 mm at internal supports for continuous members. Subscript values indicate the minimum additional bearing length where required to be greater than 35 mm at end supports and 35 mm at internal supports
5. Construction loads shall not be applied to overhangs until a 190x19 (minimum) timber fascia or other fascia of equivalent stiffness is rigidly and permanently attached to the end of rafter overhangs
6. Rafter spacing up to 1200 mm
7. **Not all sizes of SmartLVL in this table are stocked in each state.**

# Single/continuous span roof rafter - without ceiling attached

## AS 4055 classification C1-C3

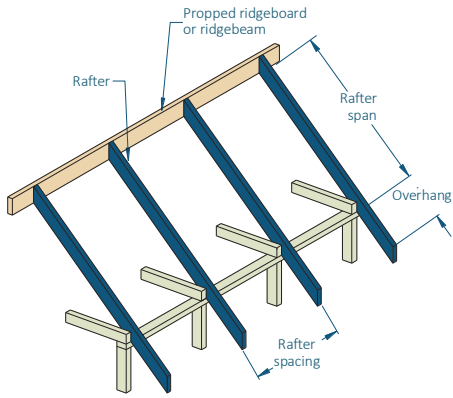

Maximum Birdsmouth = 30% of rafter depth

### EXAMPLE:

wind speed = N3

sheet roof - 40 kg/m<sup>2</sup>

rafter/truss spacing = 600 mm

rafter span = 2400 mm (single span)

Enter span table at rafter spacing of 600 mm, and read down to a span equal to or greater than 2400 mm in the 40 kg/m<sup>2</sup> row

### ADOPT:

Smart10 LVL - 120 x 35

Wind classification C1-C3									
Rafter spacing (mm)		450	600	900	1200	450	600	900	1200
Size DxB (mm)	Roof & ceiling mass (kg/m <sup>2</sup> )	Maximum recommended single span				Maximum recommended continuous span			
90x35	10	2600	2300	1700	1500	2700	2300	1700	1500
	20	2600	2300	1800	1500	2700	2300	1800	1500
	40	2400	2200	1800	1500	2800	2400	1800	1500
	60	2100	1900	1700	1500	2800	2400	1800	1600
120x35	10	3300	3100	2400	2000	3600	3100	2400	2000
	20	3300	3100	2400	2000	3700	3100	2400	2000
	40	3100	2900	2500	2100	3800	3200	2500	2100
	60	2800	2500	2200	2000	3800	3300	2600	2100
140x35	10	3700	3500	2900	2400	4300	3700	2900	2400
	20	3700	3500	2900	2400	4300	3700	2900	2400
	40	3700	3400	3000	2400	4400	3800	3000	2400
	60	3200	3000	2600	2400	4400	3900	3000	2500
170x35	10	4300	4000	3500	3000	5200	4500	3500	3000
	20	4300	4000	3600	3000	5300	4500	3600	3000
	40	4300	4000	3600	3100	5400	4600	3700	3100
	60	3900	3600	3200	2900	5300	4700	3700	3100
190x35	10	4700	4400	3900	3300	5900	5000	4000	3300
	20	4700	4400	3900	3400	5900	5100	4000	3400
	40	4700	4400	3900	3500	5900	5200	4100	3500 <sub>5</sub>
	60	4400	4000	3500	3200	5900	5300	4200	3500 <sub>10</sub>
240x35	10	5600	5200	4700	4300	7100	6400	5100 <sub>5</sub>	4300 <sub>10</sub>
	20	5600	5200	4700	4400	7100	6400	5200 <sub>10</sub>	4400 <sub>15</sub>
	40	5600	5200	4700	4400	7100	6600	5300 <sub>15</sub>	4500 <sub>20</sub>
	60	5500	5000	4400	4100	7000	6600 <sub>5</sub>	5400 <sub>20</sub>	4600 <sub>25</sub>
290x35	10	6500	6000	5400	5100	8100	7600 <sub>5</sub>	6200 <sub>15</sub>	5300 <sub>25</sub>
	20	6500	6000	5400	5100	8100	7600 <sub>5</sub>	6300 <sub>20</sub>	5300 <sub>25</sub>
	40	6500	6000	5400	5100	8100	7600 <sub>10</sub>	6400 <sub>25</sub>	5400 <sub>35</sub>
	60	6400	6000	5300	4900	8000	7500 <sub>15</sub>	6600 <sub>35</sub>	5600 <sub>45</sub>
90x45	10	2800	2500	2000	1700	3100	2600	2000	1700
	20	2800	2500	2000	1700	3100	2600	2000	1700
	40	2600	2300	2100	1800	3200	2700	2100	1800
	60	2300	2100	1800	1600	3100	2800	2100	1800
120x45	10	3500	3300	2800	2300	4200	3500	2800	2300
	20	3500	3300	2800	2300	4200	3600	2800	2300
	40	3400	3100	2700	2400	4300	3700	2900	2400
	60	3000	2700	2400	2200	4100	3700	2900	2400

## Single/continuous span roof rafter - without ceiling attached AS 4055 classification C1-C3

Wind classification C1-C3									
Rafter spacing (mm)		450	600	900	1200	450	600	900	1200
Size DxB (mm)	Roof & ceiling mass (kg/m <sup>2</sup> )	Maximum recommended single span				Maximum recommended continuous span			
140x45	10	4000	3700	3300	2700	4900	4200	3300	2700
	20	4000	3700	3300	2800	4900	4200	3300	2800
	40	3900	3600	3200	2800	5000	4300	3400	2800
	60	3500	3200	2800	2600	4800	4400	3500	2900
170x45	10	4600	4300	3900	3400	5800	5100	4100	3400
	20	4600	4300	3900	3400	5800	5100	4100	3400
	40	4600	4300	3900	3500	5800	5300	4200	3500
	60	4200	3900	3400	3100	5700	5300	4300	3600
190x45	10	5000	4700	4200	3800	6300	5700	4600	3800
	20	5000	4700	4200	3900	6300	5800	4600	3900
	40	5000	4700	4200	3900	6300	5900	4700	4000
	60	4700	4300	3800	3500	6300	5900	4800	4100
240x45	10	6000	5600	5000	4700	7500	7000	5800	4900 <sub>5</sub>
	20	6000	5600	5000	4700	7500	7000	5900	5000 <sub>5</sub>
	40	6000	5600	5000	4700	7500	7000	6000 <sub>5</sub>	5100 <sub>10</sub>
	60	5900	5400	4800	4400	7400	7000	6100 <sub>10</sub>	5200 <sub>15</sub>
290x45	10	6900	6400	5800	5400	8700	8100	7100 <sub>10</sub>	6000 <sub>15</sub>
	20	6900	6400	5800	5400	8700	8100	7200 <sub>10</sub>	6100 <sub>20</sub>
	40	6900	6400	5800	5400	8700	8100	7300 <sub>15</sub>	6200
	60	6700	6300	5800	5300	8400	8000	7300 <sub>20</sub>	6400 <sub>35</sub>

### NOTES:

1. D = member depth, B = member breadth, NS = not suitable.
2. The above table was based on a batten spacing of 900 mm
3. Maximum birdsmouth depth = 30 % of rafter depth
4. End bearing lengths = 35 mm at end supports and 35 mm at internal supports for continuous members. Subscript values indicate the minimum additional bearing length where required to be greater than 35 mm at end supports and 35 mm at internal supports
5. Construction loads shall not be applied to overhangs until a 190x19 (minimum) timber fascia or other fascia of equivalent stiffness is rigidly and permanently attached to the end of rafter overhangs
6. Rafter spacing up to 1200 mm
7. **Not all sizes of SmartLVL in this table are stocked in each state.**



# Ceiling joists

## AS 4055 wind classification N1-N4 and C1-C3

Ceiling mass 20 kg/m<sup>2</sup>

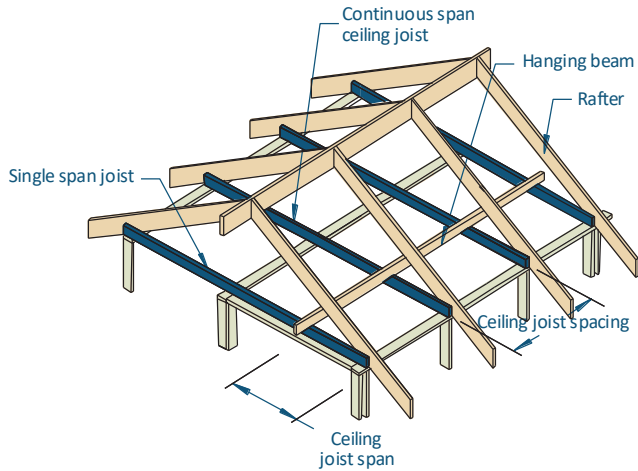

### EXAMPLE:

wind speed = N3

ceiling mass = 20 kg/m<sup>2</sup>

ceiling Joist span = 3000 mm (single span)

ceiling Joist spacing = 450 mm

Enter single span table at 450 mm in joist spacing column, read down to a span equal to or greater than 3000 mm

### ADOPT:

Smart10 LVL - 120 x 35

Ceiling joist spacing (mm)	450	600	900	1200	450	600	900	1200
Size Dx B (mm)	Maximum recommended single span				Maximum recommended continuous span			
90x35	2600	2400	2100	1800	3300	2800	2200	1800
120x35	3500	3200	2900	2500	4500	3800	3000	2500
140x35	4000	3700	3300	3000	5200	4500	3600	3000
170x35	4800	4500	4000	3700	6000	5500	4400	3700
190x35	5200	4900	4400	4100	6500	6100	4900	4200
240x35	6000	5800	5300	5000	7600	7300	6300	5300
90x45	2800	2600	2300	2100	3800	3200	2500	2100
120x45	3700	3400	3100	2800	5000	4400	3500	2900
140x45	4300	4000	3600	3300	5500	5100	4100	3400
170x45	5000	4800	4300	4000	6300	6000	5000	4200
190x45	5400	5100	4800	4400	6800	6500	5600	4800
240x45	6300	6000	5600	5300	7900	7600	7000	6100
290x45	7100	6800	6400	6000	8900	8600	8000	7400

### NOTES:

1. D = member depth, B = member breadth
2. Do not walk on joists during construction unless a construction plank is in place or over batten minimum of 35 x 70 F5
3. Minimum end/internal bearing length of 70 mm
4. **Not all sizes of SmartLVL in this table are stocked in each state. Please check with your supplier before ordering.**

# Hanging beam supporting ceiling loads only

## AS 4055 classification N1 - N4 & C1 - C3

ceiling mass - 20 kg/m<sup>2</sup>

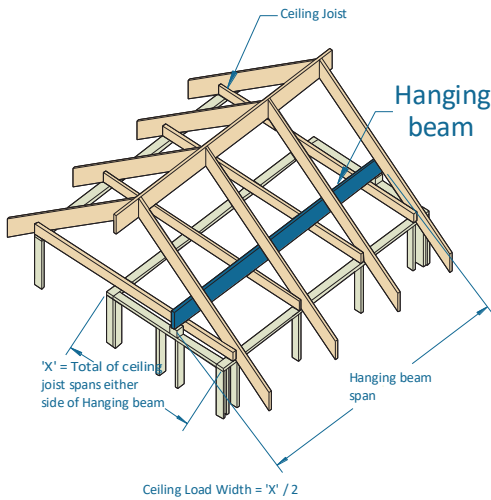

### EXAMPLE:

wind speed = N4

hanging beam span = 3500 mm

X = 5000 mm

ceiling load width = X/2 = 5000/2 = 2500 mm

Enter column at 3000 mm ceiling load width & read down to a span greater than or equal to 3500 mm

### ADOPT:

Smart10 LVL - 240x35

Ceiling load width (mm)	Wind classification N1-N4						Wind classification C1-C3					
	1800	2400	3000	3600	4200	4800	1800	2400	3000	3600	4200	4800
Size DxB (mm)	Maximum recommended hanging beam span (mm)						Maximum recommended hanging beam span (mm)					
90x35	1650	1650	1500	1400	1300	1200	1650	1450	1300	1150	1050	1000
120x35	2450	2200	2000	1850	1750	1650	2200	1900	1700	1550	1450	1350
140x35	2850	2550	2350	2150	2050	1900	2600	2250	2000	1800	1700	1550
170x35	3400	3100	2800	2600	2450	2300	3150	2700	2400	2200	2050	1900
190x35	3750	3450	3150	2950	2750	2600	3500	3050	2700	2450	2250	2100
240x35	4450	4100	3850	3650	3450	3250	4400	3800	3400	3100	2850	2700
90x45	1850	1750	1600	1500	1400	1350	1850	1650	1450	1300	1200	1150
120x45	2650	2350	2150	2000	1900	1800	2500	2150	1950	1750	1650	1500
140x45	3050	2750	2550	2350	2200	2100	2950	2550	2250	2050	1900	1750
170x45	3650	3350	3050	2850	2650	2500	3550	3050	2750	2500	2300	2150
190x45	4000	3650	3400	3150	3000	2800	3950	3450	3050	2800	2600	2400
240x45	4700	4350	4100	3900	3700	3550	4700	4350	3850	3500	3250	3050
290x45	5350	5000	4700	4450	4250	4100	5350	5000	4650	4250	3950	3650

### NOTES:

1. D = member depth, B = member breadth, NS = not suitable
2. The above table was based on a maximum ceiling mass of 20 kg/m<sup>2</sup>
3. Minimum bearing length = 70 mm at end supports
4. Restraint value for slenderness calculations is 1500 mm
5. Not all sizes of SmartLVL in this table are stocked in each state. Please check with your supplier before ordering.

# Roof battens - Supporting sheet roof

## AS 4055 wind classification N1-N4

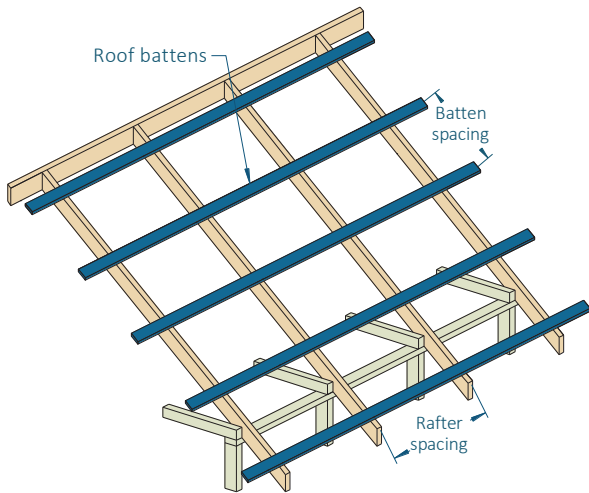

### EXAMPLE:

wind speed = N3

Battens in general area of roof

Rafter spacing = 900 mm

Batten spacing = 600 mm

Enter span table in General area of roof column, 600 mm batten spacing column, read down to a span equal to or greater than 900 mm in the wind classification N3 rows

ADOPT:

Smart10 LVL - 35 x 70

Batten Spacing (mm)	General areas						Areas within 1.2 m of an edge						Area within 1.2 m of an eaves corner					
	600		900		1200		600		900		1200		600		900		1200	
Size DxB (mm)	Maximum recommended Batten span (mm)																	
	Span	O/H	Span	O/H	Span	O/H	Span	O/H	Span	O/H	Span	O/H	Span	O/H	Span	O/H	Span	O/H
<b>Wind classification N1 - N2</b>																		
35 x 70	1200	300	1200	300	1200	300	1200	300	1200	300	1200	300	1200	300	1200	300	1200	300
35 x 90	1200	300	1200	300	1200	300	1200	300	1200	300	1200	300	1200	300	1200	300	1200	300
45 x 70	1200	300	1200	300	1200	300	1200	300	1200	300	1200	300	1200	300	1200	300	1200	300
45 x 90	1200	300	1200	300	1200	300	1200	300	1200	300	1200	300	1200	300	1200	300	1200	300
<b>Wind classification N3</b>																		
35 x 70	1200	300	1200	300	1200	300	1200	300	1200	300	1200	300	1200	300	1100	200	1000	200
35 x 90	1200	300	1200	300	1200	300	1200	300	1200	300	1200	300	1200	300	1200	300	1100	200
45 x 70	1200	300	1200	300	1200	300	1200	300	1200	300	1200	300	1200	300	1200	300	1200	300
45 x 90	1200	300	1200	300	1200	300	1200	300	1200	300	1200	300	1200	300	1200	300	1200	300
<b>Wind classification N4</b>																		
35 x 70	1200	300	1200	300	1200	300	1200	300	1100	200	900	200	1100	200	900	200	800	100
35 x 90	1200	300	1200	300	1200	300	1200	300	1200	300	1100	200	1200	300	1000	200	900	200
45 x 70	1200	300	1200	300	1200	300	1200	300	1200	300	1200	300	1200	300	1200	300	1000	200
45 x 90	1200	300	1200	300	1200	300	1200	300	1200	300	1200	300	1200	300	1200	300	1100	200

### NOTES :

1. Minimum of two (2) spans over three (3) supports. Maximum rafter spacing = 1200 mm
2. D = member depth, B = member breadth, NS = not suitable, O/H = overhang
3. Spans have been limited to 1200 mm maximum (Clause 2.1.1 AS 1720.3:2016)
4. Minimum backspan = 150 % of overhang. Maximum overhang = 25 % of backspan
5. End and internal bearing lengths = 35 mm
6. During construction, roof battens should only be walked on at support points
7. Overhangs shall not exceed 50% of actual spans
8. **Not all sizes of SmartLVL in this table are stocked in each state. Please check with your supplier before ordering.**

## Roof battens - Supporting sheet roof AS 4055 wind classification C1-C3

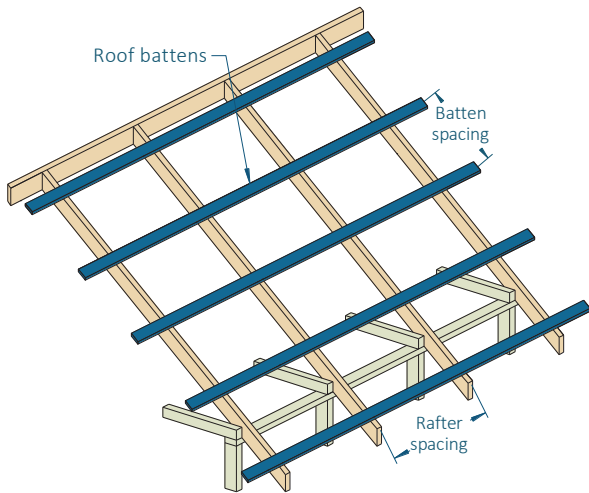

### EXAMPLE:

wind speed = C1

Battens in general area of roof

Rafter spacing = 900 mm

Batten spacing = 600 mm

Enter span table in General area of roof column, 600 mm batten spacing column, read down to a span equal to or greater than 900 mm in the wind classification N3 rows

### ADOPT:

Smart10 LVL - 35 x 70

Batten Spacing (mm)	General areas						Areas within 1.2 m of an edge						Area within 1.2 m of an eaves corner					
	600		900		1200		600		900		1200		600		900		1200	
Size DxB (mm)	Maximum recommended Batten span (mm)																	
	Span	O/H	Span	O/H	Span	O/H	Span	O/H	Span	O/H	Span	O/H	Span	O/H	Span	O/H	Span	O/H
<b>Wind classification C1</b>																		
35 x 70	1200	300	1200	300	1200	300	1200	300	1200	300	1000	200	1200	300	1000	200	900	200
35 x 90	1200	300	1200	300	1200	300	1200	300	1200	300	1200	300	1200	300	1200	300	1000	200
45 x 70	1200	300	1200	300	1200	300	1200	300	1200	300	1200	300	1200	300	1200	300	1100	200
45 x 90	1200	300	1200	300	1200	300	1200	300	1200	300	1200	300	1200	300	1200	300	1200	300
<b>Wind classification C2</b>																		
35 x 70	1200	300	1200	300	100	200	1200	300	1000	200	800	200	1000	200	800	200	700	100
35 x 90	1200	300	1200	300	1200	300	1200	300	1100	200	1000	200	1200	300	900	200	800	200
45 x 70	1200	300	1200	300	1200	300	1200	300	1200	300	1100	200	1200	300	1100	200	900	200
45 x 90	1200	300	1200	300	1200	300	1200	300	1200	300	1200	300	1200	300	1200	300	1100	200
<b>Wind classification C3</b>																		
35 x 70	1200	300	1000	200	900	200	1000	200	800	200	700	100	800	200	700	100	600	100
35 x 90	1200	300	1200	300	1200	300	1100	200	900	200	800	200	900	200	800	200	700	100
45 x 70	1200	300	1200	300	1200	300	1200	300	1000	200	900	200	1100	200	900	200	800	200
45 x 90	1200	300	1200	300	1200	300	1200	300	1200	300	1000	200	1200	300	1000	200	900	200

### NOTES :

- Minimum of two (2) spans over three (3) supports. Maximum rafter spacing = 1200 mm
- D = member depth, B = member breadth, NS = not suitable, O/H = overhang
- Spans have been limited to 1200 mm maximum (Clause 2.1.1 AS 1720.3:2016)
- Minimum backspan = 150 % of overhang. Maximum overhang = 25 % of backspan
- End and internal bearing lengths = 35 mm
- During construction, roof battens should only be walked on at support points
- Overhangs shall not exceed 50% of actual spans
- Not all sizes of SmartLVL in this table are stocked in each state. Please check with your supplier before ordering.**

## Roof battens - Tie down batten for double brick walls AS 4055 wind classification N1-N4

### EXAMPLE:

wind speed = N1

Roof load width = 1500 mm

Rafter/truss spacing = 600 mm

Tie-down spacing = 1200 mm

Enter span table in 2000 mm roof load width column, 600 mm rafter/truss spacing and read down to a tie-down spacing equal to or greater than 1200 mm in the wind classification N1 rows

### ADOPT:

**Smart10 LVL - 35 x 70**

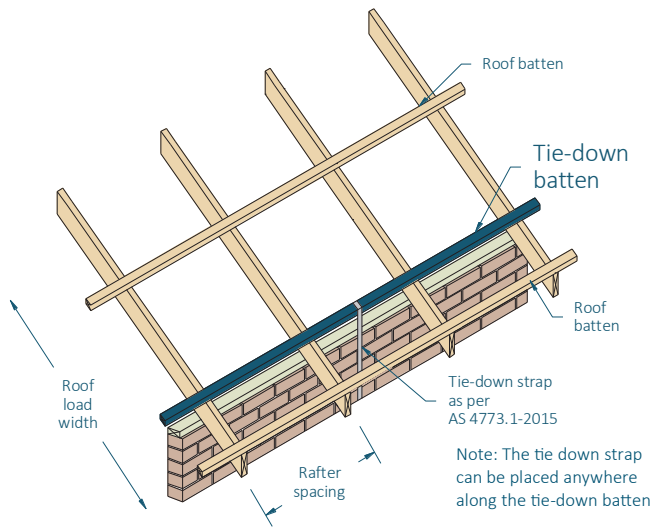

Roof load width (mm)		1000		2000		3000		4000	
Rafter/truss spacing		600	900	600	900	600	900	600	900
Size DxB (mm)	Roof mass (kg/m <sup>2</sup> )	Maximum tie-down spacing (mm)							
<b>Wind classification N1</b>									
35x70	10	1800	1900	1300	1200	1000	800	900	600
35x90		2100	2000	1400	1400	1200	1100	1000	800
45x70		2400	2300	1600	1700	1300	1300	1200	1000
45x90		2700	2600	1800	1900	1500	1500	1300	1300
<b>Wind classification N2</b>									
35x70	10	1500	1500	1100	900	800	NS	600	NS
35x90		1700	1800	1300	1200	900	800	800	NS
45x70		2000	2000	1400	1300	1200	900	900	800
45x90		2200	2200	1500	1500	1300	1200	1200	900
<b>Wind classification N3</b>									
35x70	10	1200	1200	800	NS	NS	NS	NS	NS
35x90		1300	1300	900	700	700	NS	NS	NS
45x70		1500	1500	1100	900	800	NS	600	NS
45x90		1700	1900	1300	1200	1000	800	800	NS
<b>Wind classification N4</b>									
35x70	10	900	800	NS	NS	NS	NS	NS	NS
35x90		1200	900	700	NS	NS	NS	NS	NS
45x70		1300	1200	800	NS	600	NS	NS	NS
45x90		1400	1400	1000	800	800	NS	NS	NS

### NOTES :

- Minimum of two (2) spans over three (3) supports. Maximum rafter spacing = 1200 mm
- D = member depth, B = member breadth, NS = not suitable
- RLW calculation assumes that roofing is NOT fastened to the tie-down batten. Span is conservative if roofing is fastened to the batten.
- Span have been calculated using the net pressure coefficient for areas within 1.2 m of an edge and may be conservative for roof slope >10 degrees
- End and internal bearing lengths = 35 mm
- During construction, roof battens should only be walked on at support points.
- Not all sizes of SmartLVL in this table are stocked in each state. Please check with your supplier before ordering.**

# Top plates - Not trenched - Single or upper storey loadbearing walls

## AS 4055 wind classification N1-N4

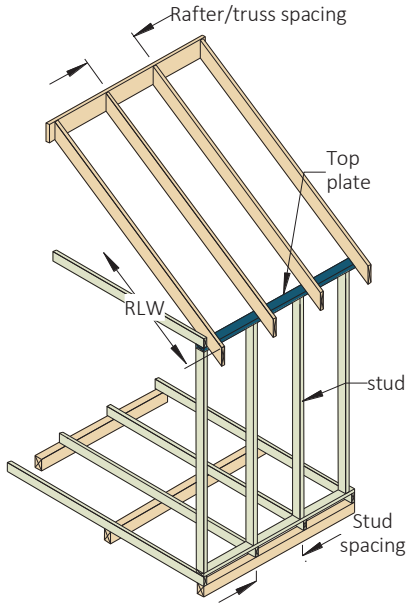

### EXAMPLE:

Sheet roof (40 kg/m<sup>2</sup>)

Wind speed = N3

Rafter/truss spacing = 600 mm

Tie down spacing = 1200 mm

Roof load width = 5000 mm

Stud spacing = 450 mm

Enter span table at 600 mm rafter/truss spacing column, 1200 mm tie down spacing column, read down to a span equal to or greater than 5000 mm in the 450 mm stud spacing row.

### ADOPT:

Smart10 LVL - 45 x 90

Rafter/truss spacing (mm)		600					900					1200				
Tie-down spacing (mm)		0	600	900	1200	1800	0	600	900	1200	1800	0	600	900	1200	1800
Size DxB (mm)	Stud spacing (mm)	Maximum recommended roof load width (mm)														
<b>Sheet roof - 40 kg/m<sup>2</sup></b>																
35x90	450	7500	7500	7100	4900	2000	6800	6100	4800	3400	2000	4700	4000	3300	2600	1900
	600	7500	7500	6800	4700	1900	4100	4100	4100	3200	1800	2800	2800	2800	2300	1700
45x90	450	7500	7500	7500	6500	2800	7500	7500	6400	5000	3500	7500	6200	4900	3400	2800
	600	7500	7500	7500	6300	2700	7500	7500	6200	4800	3400	5600	5600	4600	3200	2600
2/35x90	450	7500	7500	7500	7500	3600	7500	7500	7500	6400	4200	7500	7500	5600	4900	3400
	600	7500	7500	7500	7500	3400	7500	7500	7500	6200	4100	5800	5800	5300	4600	3200
2/45x90	450	7500	7500	7500	7500	5100	7500	7500	7500	7500	5800	7500	7500	7500	7200	4300
	600	7500	7500	7500	7500	4900	7500	7500	7500	7500	5600	7500	7500	7500	7000	4100
<b>Tiled roof - 90 kg/m<sup>2</sup></b>																
35x90	450	5500	5500	5500	5500	2700	3000	3000	3000	3000	2400	2400	2400	2400	2400	1800
	600	3500	3500	3500	3500	2400	1800	1800	1800	1800	1800	NS	NS	NS	NS	NS
45x90	450	7500	7500	7500	7500	3500	5900	5900	5900	5900	4100	4800	4800	4800	4600	2600
	600	7500	7500	7500	7500	3300	3900	3900	3900	3900	3800	2700	2700	2700	2700	2300
2/35x90	450	7500	7500	7500	7500	4200	6000	6000	6000	6000	4700	5000	5000	5000	5000	3900
	600	7100	7100	7100	7100	4000	3700	3700	3700	3700	3700	2600	2600	2600	2600	2600
2/45x90	450	7500	7500	7500	7500	6500	7500	7500	7500	7500	7100	7500	7500	7500	7500	5600
	600	7500	7500	7500	7500	6300	7500	7500	7500	7500	6800	5400	5400	5400	5400	5300

### NOTES:

1. D = member depth, B = member breadth, NS = not suitable
2. The above tables are based on a maximum roof mass of 40 and 90 kg/m<sup>2</sup>
3. Minimum bearing length = 35 mm at end supports
4. Plate sizes may be trenched up to a maximum of 3 mm. Where trenching exceeds this depth, the minimum net depth of the plate remaining shall be used when determining the allowable design limits
5. **Not all sizes of SmartLVL in this table are stocked in each state. Please check with your supplier before ordering.**

# Top plates - Not trenched - Single or upper storey loadbearing walls AS 4055 wind classification C1-C3

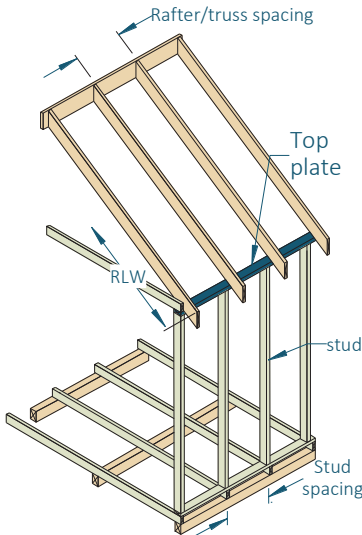

## EXAMPLE:

Sheet roof = 40 kg/m<sup>2</sup>

wind speed = C1

Rafter/truss spacing = 600 mm

Tie down spacing = 1200 mm

Roof load width = 5000 mm

Stud spacing = 450 mm

Enter span table at 600 mm rafter/truss spacing column, 1200 mm tie down spacing column, read down to a span equal to or greater than 5000 mm in the 450 mm stud spacing row.

ADOPT: Smart10 LVL - 2/45 x 90

Rafter/truss spacing (mm)		600					900					1200				
Tie-down spacing (mm)		0	600	900	1200	1800	0	600	900	1200	1800	0	600	900	1200	1800
Size DxB (mm)	Stud spacing (mm)	Maximum recommended roof load width (mm)														
<b>Sheet roof - 40 kg/m<sup>2</sup></b>																
35x90	300	7500	5100	3700	2200	NS	6500	2900	2200	2200	NS	4900	2200	NS	NS	NS
	450	6800	4900	3500	2000	NS	4100	2700	2000	2000	NS	3200	1900	NS	NS	NS
	600	5600	4700	3300	1900	NS	3300	2500	1800	1800	NS	2200	1700	NS	NS	NS
45x90	300	7500	6600	4400	2900	NS	7500	3700	2900	2200	NS	6200	2900	2200	2200	NS
	450	7500	6400	4300	2800	NS	5600	3500	2800	2100	NS	4400	2800	2100	2100	NS
	600	7400	6200	4100	2700	NS	4400	3400	2700	2000	NS	3200	2600	1900	1900	NS
2/35x90	300	7500	7500	5900	4400	2200	7500	5200	3700	2900	2200	7500	3700	2900	2200	NS
	450	7500	7500	5700	4300	2100	7200	5000	3500	2800	2100	5700	3400	2700	2000	NS
	600	7500	7500	5600	4100	2000	5800	4800	3300	2700	2000	4100	3200	2600	1900	NS
2/45x90	300	7500	7500	7500	5900	2200	7500	7400	5900	4400	3000	7500	5200	4400	3700	2200
	450	7500	7500	7500	5800	2100	7500	7200	5800	4300	2800	7500	5000	4300	3600	2100
	600	7500	7500	7500	5700	2000	7500	7000	5600	4200	2700	5900	4800	4100	3400	2000
<b>Tiled roof - 90 kg/m<sup>2</sup></b>																
35x90	300	7500	5100	3600	2900	NS	5600	2800	2800	2100	NS	4200	2100	2100	NS	NS
	450	5500	4700	3300	2700	NS	3000	2400	2400	1900	NS	2400	1800	1800	NS	NS
	600	3500	3500	3100	2400	NS	1800	1800	1800	1600	NS	NS	NS	NS	NS	NS
45x90	300	7500	7300	5100	3700	NS	7100	4400	3600	2900	NS	5200	2900	2100	2100	NS
	450	7500	7000	4900	3500	NS	4800	4100	3400	2700	NS	3800	2600	1900	1900	NS
	600	6400	6400	4700	3300	NS	3800	3800	3100	2500	NS	2600	2300	1700	1700	NS
2/35x90	300	7500	7500	5900	4400	2200	7500	5800	4400	3600	2200	7000	3600	2900	2900	NS
	450	7500	7500	5600	4200	2000	6000	5300	4000	3400	2000	4800	3200	2600	2600	NS
	600	7100	7100	5400	4000	1900	3700	3700	3700	3100	1800	2600	2600	2300	2300	NS
2/45x90	300	7500	7500	7500	6700	2900	7500	7500	5900	5200	2900	7500	5800	4400	3600	2200
	450	7500	7500	7500	6500	2800	7500	7500	5700	5000	2800	7200	5500	4100	3400	2000
	600	7500	7500	7500	6300	2700	7100	7100	5500	4700	2600	5000	5000	3900	3200	1900

## NOTES:

1. D = member depth, B = member breadth, NS = not suitable
2. The above tables are based on a maximum roof mass of 40 and 90 kg/m<sup>2</sup>
3. Minimum bearing length = 35 mm at end supports
4. Plate sizes may be trenched up to a maximum of 3 mm. Where trenching exceeds this depth, the minimum net depth of the plate remaining shall be used when determining the allowable design limits
5. **Not all sizes of SmartLVL in this table are stocked in each state. Please check with your supplier before ordering.**



## Top plates - Not trenched – Lower storey of two storey AS 4055 wind classification N1 - C3

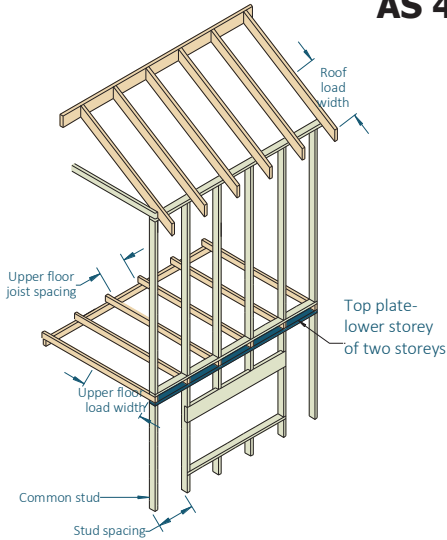

### EXAMPLE:

Tiled roof (90 kg/m<sup>2</sup>)

wind speed = N3

Upper floor load width = 1500 mm

Joist spacing = 450 mm

Roof load width = 5000 mm

Stud spacing = 450 mm

Enter span table at 1800 mm upper floor load width column, 450 mm joist spacing column, read down to a roof load width equal to or greater than 5000 mm in the 450 mm stud spacing row.

### ADOPT:

Smart10 LVL - 45 x 70

Upper floor load width (mm)		1800		3600		4800	
Joist spacing (mm)		450	600	450	600	450	600
Size DxB (mm)	Stud spacing (mm)	Maximum recommended roof load width (mm)					
<b>Sheet roof (40 kg/m<sup>2</sup>)</b>							
35x70	450	7500	4100	NS	NS	NS	NS
	600	3000	NS	NS	NS	NS	NS
45x70	450	7500	7500	7500	4100	7500	NS
	600	7500	7500	6800	NS	NS	NS
2/35x70	450	7500	7500	7500	7500	7500	6400
	600	7500	6800	7500	2500	4500	NS
2/45x70	600	7500	7500	7500	7500	7500	7500
	450	7500	7000	6800	NS	NS	NS
35x90	450	7500	7000	6800	NS	NS	NS
	600	5500	2400	NS	NS	NS	NS
45x90	450	7500	7500	7500	7500	7500	4800
	600	7500	7500	7500	4300	7500	NS
2/35x90	450	7500	7500	7500	7500	7500	7500
	600	7500	7500	7500	6000	7500	3000
2/45x90	600	7500	7500	7500	7500	7500	7500
	<b>Tiled roof (40 kg/m<sup>2</sup>)</b>						
35x70	450	4100	1900	NS	NS	NS	NS
45x70	450	7500	5400	6600	2000	3800	NS
	600	5600	3400	3000	NS	NS	NS
2/35x70	450	7500	6000	7500	4100	7100	2800
	600	5200	3000	3200	NS	1800	NS
2/45x70	450	7500	7500	7500	7500	7500	7500
	600	7500	7500	7500	7100	7500	6000
35x90	450	6000	3000	2800	NS	NS	NS
	600	2400	NS	NS	NS	NS	NS
45x90	450	7500	7500	7500	5100	7500	2200
	600	7500	5000	6000	2300	3400	NS
2/35x90	450	7500	7500	7500	6600	7500	5200
	600	7500	4500	5200	2700	4000	NS
2/45x90	600	7500	7500	7500	7500	7500	7500

### NOTES:

- D = member depth, B = member breadth, NS = not suitable
- The above tables are based on a maximum roof mass of 40 and 90 kg/m<sup>2</sup> Total upper floor mass of 50 kg/m<sup>2</sup>. Floor live load of 1.5 kPa, Floor point load of 1.1 kN
- Minimum bearing length = 35 mm at end supports
- Plate sizes may be trenched up to a maximum of 3 mm. Where trenching exceeds this depth, the minimum net depth of the plate remaining shall be used when determining the allowable design limits
- Not all sizes of SmartLVL in this table are stocked in each state. Please check with your supplier before ordering.



**SMARTFRAME**<sup>®</sup>  
POWERED BY INNOVATION



Sales 1800 33 77 03  
Technical support 1300 668 690



[tilling.com.au](https://tilling.com.au)